



**Hewlett Packard**  
Enterprise

# Aruba 2540 Switches

## Installation and Getting Started Guide

### **Abstract**

This document contains information on installing the Aruba 2540 switches and performing initial switch configuration.

Part Number: 5200-2084  
Published: October 2016  
Edition: 1

© Copyright 2016 Hewlett Packard Enterprise Development LP

The information contained herein is subject to change without notice. The only warranties for Hewlett Packard Enterprise products and services are set forth in the express warranty statements accompanying such products and services. Nothing herein should be construed as constituting an additional warranty. Hewlett Packard Enterprise shall not be liable for technical or editorial errors or omissions contained herein.

Links to third-party websites take you outside the Hewlett Packard Enterprise website. Hewlett Packard Enterprise has no control over and is not responsible for information outside the Hewlett Packard Enterprise website.

Confidential computer software. Valid license from Hewlett Packard Enterprise required for possession, use, or copying. Consistent with FAR 12.211 and 12.212, Commercial Computer Software, Computer Software Documentation, and Technical Data for Commercial Items are licensed to the U.S. Government under vendor's standard commercial license.

#### **Acknowledgments**

Microsoft® and Windows® are trademarks of the Microsoft group of companies.

#### **Applicable Products**

Aruba 2540 24G 4SFP+ Switch	JL354A
Aruba 2540 48G 4SFP+ Switch	JL355A
Aruba 2540 24G PoE+ 4SFP+ Switch	JL356A
Aruba 2540 48G PoE+ 4SFP+ Switch	JL357A

---

Hewlett Packard Enterprise

3000 Hanover Street

Palo Alto, CA 94304

<http://www.hpe.com/networking>

# Contents

<b>1</b>	<b>Introducing the 2540 switches</b>	<b>6</b>
	Front of the switches	6
	Network ports	7
	Management ports	8
	Console Ports	8
	Switch and port LEDs on the front of the switches	8
	LED Mode select button and indicator LEDs	11
	Reset and Clear buttons	12
	Back of the switches	12
	Power connector	13
	Switch features	13
<b>2</b>	<b>Installing the switch</b>	<b>15</b>
	Included parts	15
	Installation procedures	16
	Summary	16
	Installation precautions	17
	1. Prepare the installation site	17
	2. Verify the switch passes self test	18
	LED Behavior	19
	3. Mount the switch	19
	Mounting an Aruba 2540 switch	19
	Rack mount option:	19
	Horizontal surface mount option:	21
	4. Installing or removing SFP/SFP+ transceivers	21
	Installing transceivers:	22
	Removing transceivers:	22
	5. Connect the switch to a power source	22
	6. (Optional) Connect a management console	23
	Terminal configuration	24
	Direct console access	24
	Console cable pinouts	25
	7. Connect the network cables	26
	Using the RJ-45 connectors	26
	Connecting cables to SFP/SFP+ transceivers	26
	Sample network topologies	28
	As a desktop switch implementing PoE	28
	As a segment switch implementing PoE	29
<b>3</b>	<b>Getting started with switch configuration</b>	<b>30</b>
	Recommended minimal configuration	30
	Using the console setup screen	30
	Where to go from here	32
	Software updates	32
	To recover from a lost manager password:	32
	Using the IP address for remote switch management	32
	Starting a Telnet session	32
	Starting a web browser session	33
<b>4</b>	<b>Troubleshooting</b>	<b>34</b>
	Basic troubleshooting tips	34
	Diagnosing with the LEDs	35
	LED patterns for general switch troubleshooting	35

Diagnostic tips: .....	36
LED patterns for PoE troubleshooting .....	37
Diagnostic Tips: .....	38
Proactive networking .....	38
Hardware diagnostic tests .....	38
Testing the switch by resetting it .....	38
Checking the switch LEDs .....	39
Checking console messages .....	39
Testing twisted-pair cabling .....	39
Testing switch-to-device network communications .....	39
Testing end-to-end network communications .....	39
Restoring the factory default configuration .....	39
Downloading new switch software .....	40
Hewlett Packard Enterprise Customer Support Services .....	40
<b>5 Specifications .....</b>	<b>41</b>
Switch specifications .....	41
Physical .....	41
Electrical .....	41
Environmental .....	41
Acoustics .....	41
Safety .....	42
EMC .....	42
Standards .....	42
<b>6 Cabling and technology information .....</b>	<b>43</b>
Cabling specifications .....	43
Technology distance specifications .....	44
Mode conditioning patch cord .....	44
Installing the patch cord .....	45
Twisted-pair cable/connector pinouts .....	45
The Auto-MDIX feature: .....	45
Other wiring rules: .....	46
Straight-through twisted-pair cable for 10 Mbps or 100 Mbps network connections .....	46
Cable diagram .....	46
Pin assignments .....	47
Crossover twisted-pair cable for 10 Mbps or 100 Mbps network connection .....	47
Cable diagram .....	47
Pin assignments .....	47
Straight-through twisted-pair cable for 1000 Mbps network connections .....	47
Cable diagram .....	48
Pin assignments .....	48
<b>7 Support and other resources .....</b>	<b>49</b>
Accessing Hewlett Packard Enterprise support .....	49
Before calling support .....	49
Accessing updates .....	49
Websites .....	50
Customer self repair .....	50
Remote support .....	50
Documentation feedback .....	51
<b>8 Warranty and regulatory information .....</b>	<b>52</b>
Warranty information .....	52
Regulatory information .....	52
Turkey RoHS material content declaration .....	52
Ukraine RoHS material content declaration .....	52

Index ..... 53

# 1 Introducing the 2540 switches

The Aruba 2540 are multiport switches that can be used to build high-performance switched networks. These switches are store-and-forward devices offering low latency for high-speed networking. The 2540 switches also support Power over Ethernet (PoE/PoE+) technologies and full network management capabilities.

These switches are described in this manual:

## Non-PoE switches

Aruba 2540 24G 4SFP+ Switch (JL354A)

Aruba 2540 48G 4SFP+ Switch (JL355A)

## PoE+ switches

Aruba 2540 24G PoE+ 4SFP+ Switch (JL356A)

Aruba 2540 48G PoE+ 4SFP+ Switch (JL357A)

This chapter describes these switches with the following information:

- Front of the switches:
  - Network ports
  - Management ports
  - LEDs
  - Buttons
- Back of the switches:
  - Power connectors
- Switch features

## Front of the switches

Figure 1 Front of all the 2540 switches



Table 1 Front of all the 2540 switches

Label	Description
1	Aruba 2540 24G 4SFP+ Switch (JL354A)
2	Aruba 2540 48G 4SFP+ Switch (JL355A)

**Table 1 Front of all the 2540 switches (continued)**

Label	Description
3	Aruba 2540 24G PoE+ 4SFP+ Switch (JL356A)
4	Aruba 2540 48G PoE+ 4SFP+ Switch (JL357A)

**Figure 2 Example of the Front of the 2540 switches labels and descriptions**

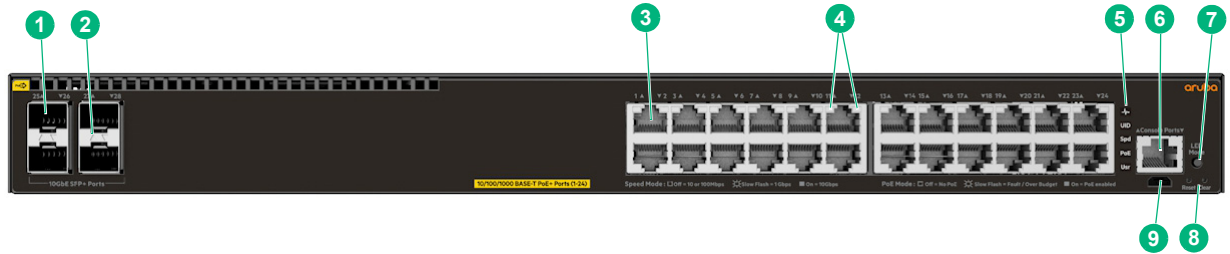

**Table 2 Front of the 2540 switches labels and descriptions**

Label	Description
1	SFP+ ports
2	SFP+ port LEDs
3	10/100/1000Base-T RJ-45 ports
4	Switch port LEDs
5	Global Status, Unit Identification, Speed, PoE*, Usr LEDs
6	RJ Serial Console
7	LED Mode button
8	Reset, Clear buttons
9	Micro USB Console

\* PoE Mode LED is present only on switch models that support PoE.

## Network ports

**Table 3 Network ports**

Product number	Model name	10/100/1000 non-PoE RJ-45 ports <sup>1</sup>	10/100/1000 PoE/PoE+ RJ-45 ports <sup>1</sup>	SFP+ ports <sup>2</sup>
JL354A	Aruba 2540 24G 4SFP+ Switch	24		4
JL355A	Aruba 2540 48G 4SFP+ Switch	48		4
JL356A	Aruba 2540 24G PoE+ 4SFP+ Switch		24	4
JL357A	Aruba 2540 48G PoE+ 4SFP+ Switch		48	4

**Notes:**

<sup>1</sup> All RJ-45 ports support “Auto-MDIX”, which means you can use either straight-through or crossover twisted-pair cables to connect network devices to the switch.

<sup>2</sup> SFP+ ports support 100Mb (100-FX), 1G SFP, and 10G SFP+ transceivers.

These products also support optional network connectivity:

**Table 4 Optional network connectivity, speeds and technologies**

			Transceiver form-factor and connector <sup>1</sup>	
Speed	Technology	Cabling	SFP ("mini-GBIC") Connector	SFP+ connector
100 Mbps	100-FX	Fiber (multimode)	LC	
	1000-T	Copper (twisted-pair)	RJ-45	
1000 Mbps	1000-SX	Fiber (multimode)	LC	
	1000-LX	Fiber (multimode or single mode)	LC	
	1000-LH	Fiber (single mode)	LC	
	1000-BX	Fiber (single mode)	LC	
	10-Gig Direct Attach	Copper (twinaxial)		Not applicable
10 Gbps	10-Gig SR	Fiber (multimode)		LC
	10-Gig LR	Fiber (single mode)		LC
	10-Gig ER	Fiber (single mode)		LC

<sup>1</sup> For supported transceivers, visit <http://www.hpe.com/networking/support>.

- In the first textbox, type **J4858** (for 100-Mb and Gigabit information), or **J8436** (for 10-Gigabit information).
- Select any of the products that display in the dropdown list and click on **Show Selected Items**.
- Select **Support Center**. Then click on **Manuals**, followed by **View All** to find the **Transceiver Support Matrix**.

For technical details of cabling and technologies, see “[Cabling and technology information](#)” (page 43).

## Management ports

### Console Ports

There are two serial console port options on the switch, an RJ-45 or Micro USB. These ports are used to connect a console to the switch either by using the RJ-45 serial cable supplied with the switch, or a standard Micro USB cable (not supplied). The Micro USB connector has precedence for input. If both cables are plugged in, the console output is echoed to both the RJ-45 and the Micro-USB ports, but the input is only accepted from the Micro-USB port.

For more information on the console connection, see “[6. \(Optional\) Connect a management console](#)” (page 23). The console can be a PC or workstation running a VT-100 terminal emulator, or a VT-100 terminal.

### Switch and port LEDs on the front of the switches

- [Table 5 \(page 9\)](#) describes the switch chassis LEDs and also the Switch Mode LEDs.
- [Table 6 \(page 9\)](#) describes the switch Port LEDs and their different mode behaviors.



**Figure 3 Chassis LEDs for the 2540 switches**

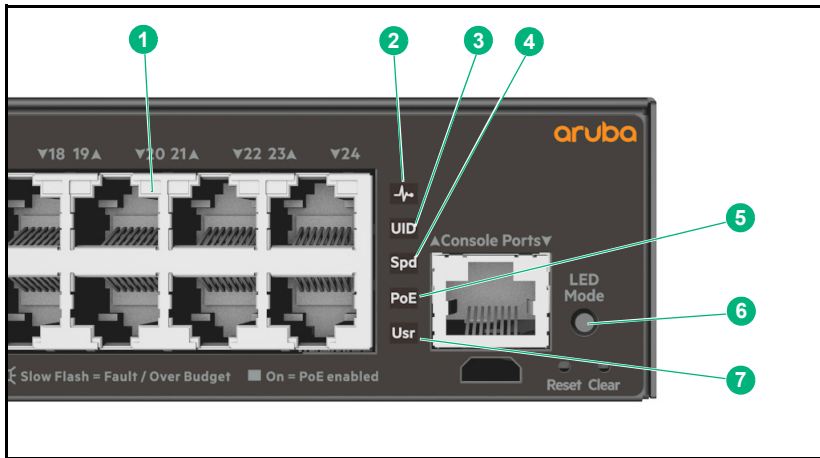

**Table 5 Switch chassis LEDs**

Label	Description
1	Switch port LEDs
2	Global status LED
3	Unit identification LED
4	Speed LED
5	PoE LED*
6	LED Mode button
7	Usr LED

\* PoE Mode LED is present only on switch models that support PoE.

**Table 6 Front of switch status and mode LED behavior**

Switch LEDs	Function	State	Meaning
Global Status	Internal power status of the switch. Self-test status Switch/port fault status	On green	The switch has passed self-test and is powered up normally.
		Slow flash green*	The switch self-test and initialization are in progress after the switch has been power cycled or reset. The switch is not operational until this LED stops blinking green.
		Slow flash orange*	A fault or self-test failure has occurred on the switch, one of the switch ports, or a fan. The Status LED for the component with the fault will flash simultaneously.
		On orange	If this LED is on orange for a prolonged time, the switch has encountered a fatal hardware failure, or has failed its self-test.
		Off	The unit is not receiving power.

**Table 6 Front of switch status and mode LED behavior (continued)**

Switch LEDs	Function	State	Meaning
UID (Unit Identification)	The Unit Identification LED is used to help you to identify a particular unit in a rack or collection of products.	On or slow flash*	The "chassislocate" command allows you to blink or turn on the LED for a specified number of minutes (1-1440). The default is 30 minutes.
		Off	LED will turn off after the timeout period has expired.
Speed mode selected	Indicates when the port LEDs are showing port speed information.	On	Speed mode is selected. Port LEDs indicate port speed.
		Off	Speed mode not selected.
Power over Ethernet (PoE) mode selected**	Indicates when the port LEDs are showing PoE status information.	On green	PoE Mode is selected. Port LEDs show PoE information.
		On orange	PoE mode is selected and a port also has a PoE error. The Global Status LED and the LED corresponding to the port with the error will be flashing orange. The rest of the port LEDs will display normal PoE status.
		Slow flash orange*	PoE mode has NOT been selected and a port has a PoE error. LED will be flashing orange simultaneously with the Global Status LED and the LED corresponding to the port with the error. The rest of the port LEDs will display normal PoE status.
		Off	PoE mode is not selected.
User mode selected	This mode is reserved for future use.	On green	User mode is selected.
		Off	User mode not selected.

\* The slow blink behavior is an on/off cycle once every 1.6 seconds, approximately.  
 \*\* Applies only to switches that support PoE/PoE+.

**Table 7 Port LEDs and mode behavior**

Switch LEDs	Function	State/Mode	Meaning
Port LEDs	To display the information for the port as selected by the LED Mode select button.  When transceivers and SFPs are installed, this LED is also used to indicate that the installation has occurred by going on for two seconds then off.	Activity/Link	Shows port Activity and Link status.  This is the DEFAULT. There is no dedicated mode LED indicating this mode.  The Mode LED function should return to this selection 10 minutes after the last press of the LED Mode button.
		Speed	Shows port speed configuration.
		PoE***	Shows PoE information.
		User	Shows user selectable user behavior.

**Table 7 Port LEDs and mode behavior (continued)**

Switch LEDs	Function	State/Mode	Meaning
Activity/Link mode selected	Port LEDs are displaying link status and network activity information simultaneously. Activity/Link mode is the default mode and is in effect unless another LED mode has been selected.	Half-bright green	The port is enabled and receiving a link indication from the connected device.
		Activity flicker green	The percentage of time that the LED is full-bright is roughly proportional to the percentage of full-bandwidth utilization of the port. Half-bright green port link indication remains on as activity flickers from half-bright to full-bright.
		Slow Flash Orange*	The corresponding port has failed its self-test. Flashes simultaneously with the Global Status LED flashing orange.
		Off	The port is disabled, not connected, or not receiving a link.
Speed mode selected	Port LEDs are displaying the connection speed at which each port is operating.	On Green	The port is operating at 10 Gbps.
		Slow Flash Green*	The port is operating at 1 Gbps.
		Off	The port is not Linked, or is operating at 10 or 100 Mbps.
PoE mode selected***	Port LEDs are displaying PoE information.	On Green	The port is providing PoE power.
		On Orange	PoE is disabled on the port.
		Fast Flash Orange**	The port is denied power or is detecting an external PD fault.
		Slow Flash Orange*	The port has an internal hardware failure. Flashes simultaneously with the Global Status LED flashing orange.
		Off	The port is not providing PoE power.

\* The slow blink behavior is an on/off cycle once every 1.6 seconds, approximately.  
 \*\* The fast blink behavior is an on/off cycle once every 0.8 seconds, approximately.  
 \*\*\* Applies only to switches that support PoE/PoE+.

## LED Mode select button and indicator LEDs

The state of the Mode LEDs is controlled by the LED Mode select button. The current view mode is indicated by the Mode LEDs next to the button. Press the button to step from one view mode to the next. See the LED information in [Table 6 \(page 9\)](#).

## Reset and Clear buttons

The Reset and Clear buttons are recessed from the front panel (to protect them from being pushed accidentally) and are accessible through small holes on the top of the front panel. Use pointed objects, such as unbent paper clips, to push them.

The Reset and Clear buttons are used singly or in combination, as follows:

To accomplish this:	Do this:	This will happen:
Soft Reset	Press and release the Reset button	The switch operating system is cleared gracefully (such as data transfer completion, temporary error conditions are cleared), then reboots and runs self tests.
Hard Reset	Press and hold the Reset button for more than 5 seconds (until all LEDs turn on), then release.	The switch reboots, similar to a power cycle. A hard reset is used, for example, when the switch CPU is in an unknown state or not responding.
Delete console and management access passwords	Press Clear button for more than 5 seconds, but within 15 seconds (in between 5 - 15 seconds)	Clears all passwords. Will flash Global Status Green LED, after 5 seconds has expired to indicate passwords have cleared.
Turn off UID LED	Press Clear button and release within 5 seconds (in between 0.5 - 5 seconds)	Clears the UID LED.
Restore the factory default configuration	<ol style="list-style-type: none"> <li>1. Press Clear and Reset simultaneously.</li> <li>2. While continuing to press Clear, release Reset.</li> <li>3. When the Global Status LED begins to fast flash orange (after approximately 5 seconds), release Clear.</li> </ol>	The switch removes all configuration changes, restores the factory default configuration, and runs self test.

Note: These buttons are provided for your convenience. If you are concerned with switch security, make sure that the switch is installed in a secure location, such as a locked wiring closet. You can also disable these buttons by using the **front-panel-security** command. See the *2540 Management and Configuration Guide* for a description of that command.

## Back of the switches

The back of all the 24-port and 48-port switches are the same.

**Figure 4 Back of the 2540 switches**



**Table 8 Back of the 2540 switches labels and descriptions**

Label	Description
1	Ground point
2	AC power connector
3	Cable tie eyelet

## Power connector

The 2540 switches do not have a power switch; they are powered on when connected to an active AC power source. The switches automatically adjust to any voltage between 100-127 and 200-240 volts and either 50 or 60 Hz. There are no voltage range settings required.

## Switch features

The features of the 2540 Switches include:

- Combinations of fixed 10/100/1000-T and SFP+ ports, as described under “[Network ports](#)” (page 7).
- Power over Ethernet (PoE+) operation (JL356A, JL357A)—The PoE+ switches are IEEE 802.3at standard compliant and provide up to 30W per port to power IP phones, wireless access points, indoor web cameras, and more. For more information, see the *HPE Power over Ethernet (PoE/PoE+) Planning and Implementation Guide*, available from [www.hpe.com/networking/ResourceCenter](http://www.hpe.com/networking/ResourceCenter).

The switches support 802.3af and 802.3at standard devices and some pre-standard PoE devices. For a list of these devices, see the FAQs (Frequently Asked Questions) for your switch model. PoE is enabled by default. (For more information, see the *2540 Management and Configuration Guide* for your switch at [www.hpe.com/networking/ResourceCenter](http://www.hpe.com/networking/ResourceCenter).

- Plug-and-play networking. All ports are enabled by default, just connect the network cables to active network devices and your switched network is operational.
- Auto MDI/MDI-X on all twisted-pair ports (10/100/1000Base-T), meaning that all connections can be made using straight-through twisted-pair cables. Cross-over cables are not required, although they will also work. The pin operation of each port is automatically adjusted for the attached device: if the switch detects that another switch or hub is connected to the port, it configures the port as MDI; if the switch detects that an end-node device is connected to the port, it configures the port as MDI-X. (See “[Cabling and technology information](#)” (page 43) for recommended or required cabling.)
- Automatic learning of the network addresses in each switch’s 64000-address forwarding table (with configurable address aging value).
- Automatically negotiated full-duplex operation for the 10/100/1000 RJ-45 ports when connected to other auto-negotiating devices. The SFP+ ports always operate at full duplex.
- Easy management of the switch through several available interfaces:
  - **Console interface**—A full featured, easy to use, VT-100 terminal interface for out-of-band or in-band switch management.
  - **Web browser interface**—An easy to use built-in graphical interface that can be accessed from common web browsers.
  - **Aruba AirWave**—A powerful and easy-to-use network operations system that manages wired and wireless infrastructures. For more information, go to [www.arubanetworks.com/products/networking/management/airwave](http://www.arubanetworks.com/products/networking/management/airwave).
  - **IMC (Intelligent Management Center)**—An SNMP-based, graphical network management tool that you can use to manage your entire network. Free trials of IMC can be downloaded at <http://www.hpe.com/networking/imc>.
- Support for the Spanning Tree Protocol to eliminate network loops.
- Support for up to 4096 IEEE 802.1Q-compliant VLANs so you can divide the attached end nodes into logical groupings that fit your business needs.
- Support for many advanced features to enhance network performance. For a description, see the *2540 Management and Configuration Guide* at [www.hpe.com/networking/ResourceCenter](http://www.hpe.com/networking/ResourceCenter).

- To download product updates, go to either of the following:
  - Hewlett Packard Enterprise Support Center **Get connected with updates** page: [www.hpe.com/support/e-updates](http://www.hpe.com/support/e-updates)
  - HPE Networking Software: [www.hpe.com/networking/software](http://www.hpe.com/networking/software)
  - To view and update your entitlements, and to link your contracts and warranties with your profile, go to the Hewlett Packard Enterprise Support Center **More Information on Access to Support Materials** page: [www.hpe.com/support/AccessToSupportMaterials](http://www.hpe.com/support/AccessToSupportMaterials)
- Low power operation:
  - Ports on a switch may be set to operate at reduced power.
  - Port status LEDs may be turned off.
  - RJ-45 ports operate at reduced power if they are not connected (link partner is not detected).

## 2 Installing the switch

This chapter shows how to install the switch. The Aruba 2540 switches come with an accessory kit that includes the brackets for mounting the switch in a standard 19-inch telco rack, in an equipment cabinet, and with rubber feet that can be attached so the switch can be securely located on a horizontal surface. The brackets are designed to allow mounting the switch in a variety of locations and orientations. For other mounting options contact your local Hewlett Packard Enterprise authorized network reseller or Hewlett Packard Enterprise representative.

**NOTE:** If an Aruba 2540 switch is to be shipped in a rack, it can be mounted and shipped in a Hewlett Packard Enterprise 10K rack using the HPE X410 Universal Rack Mounting Kit (J9583A). Additionally, it can also be mounted in any four post rack using the HPE X410 Universal Rack Mounting Kit (J9583A).

### Included parts

The 2540 switches have the following components shipped with them:

- *Aruba Switch Quick Setup Guide and Safety/Regulatory Information*
- *Switch Safety and Regulatory sheet*
- Warranty notice
- *General Safety and Regulatory booklet*
- Accessory kits and console cable

Aruba 2540 switch model	Part number	Count	Included items
JL356A 24G PoE+ 4SFP+ Switch	5092-0727	2	Rack mount brackets
JL357A 48G PoE+ 4SFP+ Switch		4	Rubber foot pads
JL354A 24G 4SFP+ Switch	5092-0769	1	Cable tie
JL355A 48G 4SFP+ Switch		8	Small screws; bracket-to-switch
		4	Large screws; bracket-to-rack
All Aruba 2540 switch models	5188-3836	1	Console cable

- There are two warranty documents. One is the HPN warranty and the other is the EG warranty.
  - 5998-5984 Warranty Statement and Software License
  - 703828-025 EG Safety, Compliance, and Warranty Information
- Power cord, one of the following

Argentina	8121-0729	Israel	8121-1004
Australia/New Zealand	8121-0837	Japan	8121-1143
Brazil	8121-1071	Switzerland	8121-0738
Chile	8121-0735	South Africa	8121-0737
China	8121-0943	Taiwan	8121-0964
Continental Europe/South Korea	8121-0731	Philippines/Thailand	8121-0734
Denmark	8121-0733	UK/Hong Kong/Singapore/Malaysia	8121-0739
India	8121-0564	US/Canada/Mexico	8121-1141

製品には、同梱された電源コードをお使い下さい。  
同梱された電源コードは、他の製品では使用出来ません。

# Installation procedures

## Summary

1. **Prepare the installation site** (“1. Prepare the installation site” (page 17)). Ensure the physical environment into which you will be installing the switch is properly prepared, including having the correct network cabling ready to connect to the switch and having an appropriate location for the switch. See “Installation precautions” (page 17) for some installation precautions.
2. **Verify the switch passes self test** (“2. Verify the switch passes self test” (page 18)). Plug the switch into a power source and observe that the LEDs on the switch’s front panel indicate correct switch operation. When self test is complete, unplug the switch.
3. **Mount the switch** (“3. Mount the switch” (page 19)). The switch can be mounted in a 19-inch telco rack, in an equipment cabinet, or on a horizontal surface.
4. **(Optional) Install SFP/SFP+ transceivers** (“4. Installing or removing SFP/SFP+ transceivers” (page 21)). The switch has two or four slots for installing SFP/SFP+ transceivers. Depending on where you install the switch, it may be easier to install the transceivers first. Transceivers can be hot swapped—they can be installed or removed while the switch is powered on.
5. **Connect power to the switch** (“5. Connect the switch to a power source” (page 22)). Once the switch is mounted, plug it into the main power source.
6. **(Optional) Connect a management console to the switch** (“6. (Optional) Connect a management console” (page 23)). You may want to modify the switch’s configuration, for example, to configure an IP address so it can be managed using a Web browser, from an SNMP network management station, or through a Telnet session. Configuration changes can be made by using the included console cable to connect a PC to the switch’s console port.
7. **Connect the network devices** (“7. Connect the network cables” (page 26)). Using the appropriate network cables, connect the network devices to the switch ports.

At this point, your switch is fully installed. See the rest of this chapter if you need more detailed information on any of these installation steps.



## Installation precautions

---

### △ **WARNING!**

- The rack or cabinet should be adequately secured to prevent it from becoming unstable and/or falling over.
  - Devices installed in a rack or cabinet should be mounted as low as possible, with the heaviest devices at the bottom and progressively lighter devices installed above.
- 

### △ **CAUTION:**

- When installing the switch, the AC outlet should be near the switch and should be easily accessible in case the switch must be powered off.
  - Ensure the power source circuits are properly grounded, then use the power cord supplied with the switch to connect it to the power source.
  - Use only approved power cords with your Aruba Networking Product. Please see the power cord information in the section titled [“Included parts” \(page 15\)](#) of this guide for acceptable power cords that are appropriate for this product. Failure to use approved power cords can result in personal injury and product damage, and may void your product warranty.
  - Use only the AC/DC power adapter and power cord (if applicable), supplied with the switch. Use of other adapters or power cords, including those that came with other Hewlett Packard Enterprise products, may result in damage to the equipment.
  - If your installation requires a different power cord than the one supplied with the switch and power supply, be sure the cord is adequately sized for the switch’s current requirements. In addition, be sure to use a power cord displaying the mark of the safety agency that defines the regulations for power cords in your country. The mark is your assurance that the power cord can be used safely with the switch and power supply.
  - When installing the switch, the AC outlet should be near the switch and should be easily accessible in case the switch must be powered off.
  - Ensure the switch does not overload the power circuits, wiring, and over-current protection. To determine the possibility of overloading the supply circuits, add together the ampere ratings of all devices installed on the same circuit as the switch and compare the total with the rating limit for the circuit. The maximum ampere ratings are usually printed on the devices near the AC power connectors.
  - Do not install the switch in an environment where the operating ambient temperature might exceed its specification. This includes a fully-enclosed rack. Ensure the air flow around the sides and back of the switch is not restricted. Leave at least 3 inches (7.6 cm) for cooling for the switches when installed in a fully-enclosed rack.
- 

## 1. Prepare the installation site

**Cabling Infrastructure** - Ensure the cabling infrastructure meets the necessary network specifications. See appendix A, [“Cabling and technology information” \(page 43\)](#) for more information:

**Installation Location** - Before installing the switch, plan its location and orientation relative to other devices and equipment:

- In the front of the switch, leave at least 3 inches (7.6 cm) of space for the twisted-pair and fiber-optic cabling.
- In the back of the switch, leave at least 1 1/2 inches (3.8 cm) of space for the power cord.
- On the sides of the switch, leave at least 3 inches (7.6 cm) for cooling.

## 2. Verify the switch passes self test

Before mounting the switch in its network location, you should first verify it is working properly by plugging it into a power source and verifying it passes its self test.

1. Connect the power cord supplied with the switch to the power connector on the back of the switch, and then into a properly grounded electrical outlet.

**Figure 5** Connecting the power cord on the Aruba 2540 switches



**NOTE:** The 2540 switches do not have a power switch. They are powered on when the power cord is connected to the switch and to a power source. For safety, the power outlet should be located near the switch installation.

The switch automatically adjusts to any voltage between 100-127 or 200-240 volts and either 50 or 60 Hz. There are no voltage range settings required.

2. Check the LEDs on the switch as described below.

**Figure 6** Example of LEDs on the 2540 switches

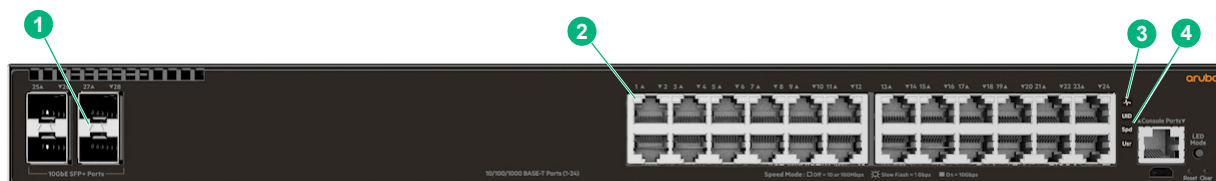

**Table 9** Example of LEDs on the 2540 switches labels and descriptions

Label	Description
1	SFP/SFP+ port LEDs
2	RJ-45 port LEDs
3	Global Status and UID LEDs
4	Mode LEDs

When the switch is powered on, it performs its diagnostic self test and initialization. This boot process, depending on switch model and configuration, takes approximately 1-2 minutes to complete.

## LED Behavior

During the switch boot:

- The **Global Status**, **UID**, other status and mode LEDs, will initially turn on green and bi-color LEDs will change to orange, then back to green.
- The **Global Status** LED will start blinking green, indicating the switch is going through its self-test and will continue to blink green until the switch is fully booted.
- The port LEDs will come on green, turn orange, turn back to green, and then may blink on and off during phases of the boot.

When the switch boots successfully, the LEDs display as follows:

- **Global Status** LED will be on solid green.
- **UID** LED is off.
- Other status LEDs may be on or off depending on the switch configuration and the hardware installed.
- The port LEDs go into their normal operating mode:
  - If the ports are connected to active network devices, the port LED may be on and behaves according to the LED mode selected. In the default LED mode (Activity/Link), the LED should show half-bright green to indicate Link and be flickering full-bright green to show network traffic.
  - If the ports are not connected to active network devices, the port LED will stay off.

If the LED display is different than what is described above, especially if the **Global Status** LED continues to blink green for more than 120 seconds or blinks orange continually, then the switch boot has not completed correctly. Refer to [“Troubleshooting” \(page 34\)](#) for diagnostic help.

## 3. Mount the switch

### Mounting an Aruba 2540 switch

The supported mounting options for the Aruba 2540 switches include:

- Rack mount
- Horizontal surface mount

Rack mount option:

The switch is designed to be mounted in any EIA-standard 19-inch telco rack or communication equipment cabinet.

The Aruba 2540 switches can also be mounted in 4-post racks and cabinets by using the X410 Switch Rail Kit (J9583A). For instructions on using the kit, see the documentation that is included with the kit.

---

**NOTE:** If an Aruba 2540 switch is to be shipped in a rack, it can be mounted and shipped in a Hewlett Packard Enterprise 10K rack using the HPE X410 Universal Rack Mounting Kit (J9583A). Additionally, it can also be mounted in any four post rack using the HPE X410 Universal Rack Mounting Kit (J9583A).

---

Some mounting brackets have multiple mounting holes and can be rotated, allowing for a wide variety of mounting options. Secure the rack in accordance with the manufacturer's safety guidelines.

**⚠ WARNING!** For safe operation, please read the mounting precautions in “[Installation precautions](#)” (page 17), before mounting a switch.

**EQUIPMENT CABINET NOTE:** The 12-24 screws supplied with the switch are the correct threading for standard EIA/TIA open 19-inch racks. If installing the switch in an equipment cabinet such as a server cabinet, use the clips and screws that came with the cabinet in place of the 12-24 screws that are supplied with the switch.

Complete step 1, and plan which four holes you will be using in the cabinet and install all four clips. Then proceed to step 2.

1. Use a #1 Phillips (cross-head) screwdriver and attach the mounting brackets to the switch with the included 8-mm M4 screws.

**Figure 7 Attaching mounting brackets to the 2540 switches**

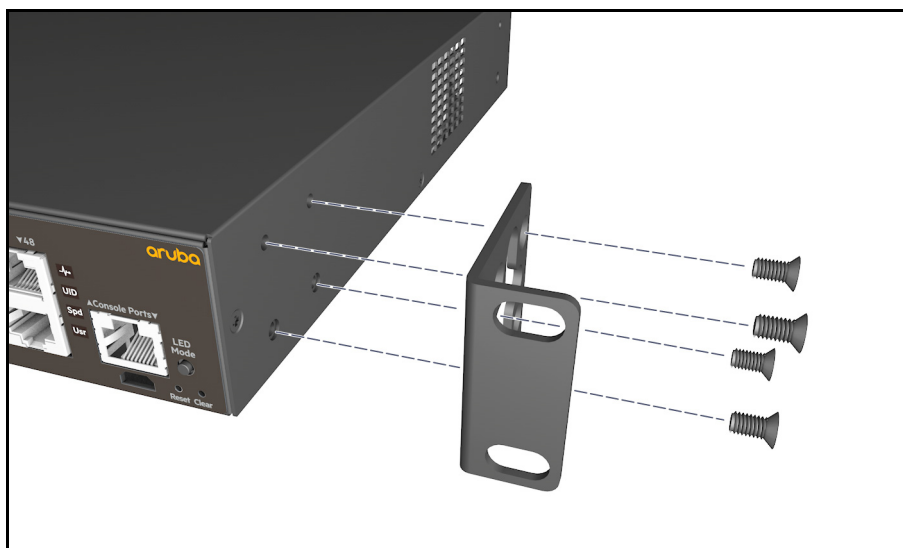

**⚠ WARNING!** For safe reliable installation, only use the screws provided in the accessory kit to attach the mounting brackets to the switch.

**NOTE:** The mounting brackets have multiple mounting holes and can be rotated allowing for a wide variety of mounting options. These include mounting the switch so that its front face is flush with the face of the rack, or mounting it in a more balanced position.

2. Hold the switch with attached brackets up to the rack and move it vertically until rack holes line up with the bracket holes, then insert and tighten the four number 12-24 screws holding the brackets to the rack.

**Figure 8 Mounting the 2540 switches in a rack**

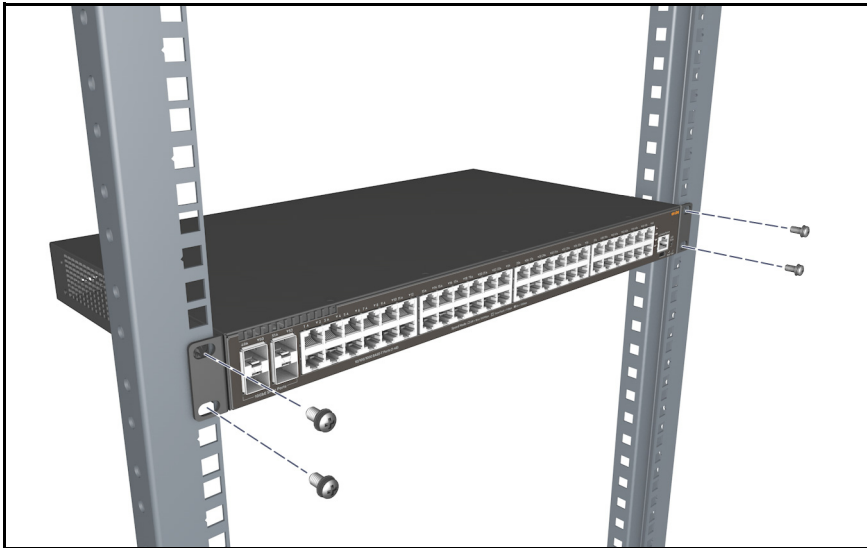

**Horizontal surface mount option:**

Place the switch on a table or other horizontal surface. The switch comes with rubber feet in the accessory kit that can be used to help keep the switch from sliding on the surface.

Attach the rubber feet to the four corners on the bottom of the switch within the embossed angled lines. Use a sturdy surface in an uncluttered area. You may want to secure the networking cables and switch power cord to the table leg or other part of the surface structure to help prevent tripping over the cords.

**Figure 9 Mounting the 2540 switches on a horizontal surface**

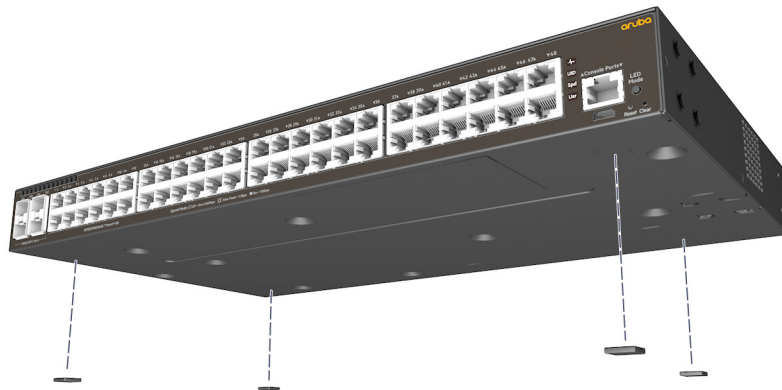

## 4. Installing or removing SFP/SFP+ transceivers

You can install or remove a transceiver from an SFP+ slot without having to power off the switch.

**NOTES:**

- The transceivers operate only at full duplex. Half duplex operation is not supported.
- Ensure the network cable is NOT connected when you install or remove a transceiver.



**CAUTION:** Use only supported genuine HPE Aruba SFP/SFP+ transceivers with your switch. Non-HPE Aruba SFP/SFP+ transceivers are not supported, and their use may result in product malfunction. Should you require additional transceivers, contact your HPE Aruba sales representative or an authorized reseller.

## Installing transceivers:

Hold the transceiver by its sides and gently insert it into either of the slots on the switch until it clicks into place. When a transceiver is inserted the switch authenticates it. This can take 1-3 seconds, with the worst case being 5 seconds. If the transceiver is removed before the authentication completes a self test failure will be reported.

---

**⚠ WARNING!** The fiber-optic HPE Aruba transceivers are Class 1 laser devices. Avoid direct eye exposure to the beam coming from the transmit port.

---

**NOTE:** Always disconnect the network cable from a transceiver before installing it in the switch.

---

**Figure 10** Installing a transceiver



## Removing transceivers:

---

**NOTE:** Always disconnect the network cable from the transceiver before removing it from the switch.

---

Depending on when the transceiver was purchased, it may have either of three different release mechanisms: a plastic tab on the bottom of the transceiver, a plastic collar around the transceiver, or a wire bail.

To remove the transceivers that have the plastic tab or plastic collar, push the tab or collar toward the switch until the transceiver releases from the switch (it will move outward slightly), then pull it from the slot.

To remove the transceivers that have the wire bail, lower the bail until it is approximately horizontal, and then using the bail, pull the transceiver from the slot.

## 5. Connect the switch to a power source

1. Plug the included power cord into the switch's power connector and into a nearby AC power source.

**Figure 11 Connecting the power cord**



2. Re-check the LEDs during self test. See [“LED Behavior” \(page 19\)](#).
3. Use the included cable tie to secure the power cord to the switch.

**Figure 12 Using the cable tie on the 2540 switches**



## 6. (Optional) Connect a management console

The switches have a full-featured, easy to use console interface for performing switch management tasks including the following:

- Monitor switch and port status and observe network activity statistics.
- Modify the switch's configuration to optimize switch performance, enhance network traffic control, and improve network security.
- Read the event log and access diagnostic tools to help in troubleshooting.
- Download new software to the switch.
- Add passwords to control access to the switch from the console, Web browser interface, and network management stations.

The console can be accessed through these methods:

- **Out-of-band:** The switches come with a serial cable for connecting a PC or VT-100 terminal, to be used as a console, directly to the switch's RJ-45 Console Port.



There is also the option of using a USB cable (not supplied) to connect the switch's Micro USB Console Port to a PC. To use the USB Console Port, you must first download a USB driver to the PC. See the Note on [page 24](#) for more information.

Note that you cannot use both the RJ-45 Console Port and USB Console Port at the same time. When the USB Console Port is connected to a live PC, it has priority over the RJ-45 Console Port.

By default, the RJ-45 console port is active (accepts input). To activate the USB console port, connect it to a live PC. If the USB console session is closed by the inactivity timer, the RJ-45 console port becomes active again to allow remote access via a terminal server. To reactivate the USB console port, unplug it, then reconnect it to a live PC.

- **In-Band:** Access the console using Telnet from a PC or UNIX station on the network, and a VT-100 terminal emulator. This method requires that you first configure the switch with an IP address and subnet mask by using either out-of-band console access or through DHCP/Bootp. For more information on IP addressing and on starting a Telnet session, see chapter 3, “[Getting started with switch configuration](#)” (page 30).

The switches can simultaneously support one out-of-band console session through a Console Port and in-band Telnet console sessions.

## Terminal configuration

To connect a console to the switch, configure the PC terminal emulator as a DEC VT-100 (ANSI) terminal or use a VT-100 terminal, and configure either one to operate with these settings:

- Any baud rate from 1200 to 115200 (the switch senses the speed).
- 8 data bits, 1 stop bit, no parity, and flow control set to off.
- For the Windows Terminal program, also disable (uncheck) the “Use Function, Arrow, and Ctrl Keys for Windows” option.
- For the Hilgraeve HyperTerminal program, select the “Terminal keys” option for the “Function, arrow, and ctrl keys act as” parameter.

If you want to operate the console using a different configuration, make sure you change the settings on both the terminal and on the switch so they are compatible. Change the switch settings first, then change the terminal settings, then reboot the switch and reestablish the console session.

---

**NOTE: USB Console Port Driver Download.** When using the Micro USB Console Port, the connected PC first requires “virtual COM port” USB drivers to be installed. USB drivers are available for Windows XP, Windows Vista, and Windows 7.

USB console drivers are available at [www.hpe.com/networking/support](http://www.hpe.com/networking/support). Type a product name (e.g. 2540) or product number in the Auto Search textbox. Select one of the switches from the drop-down list. Click the **Display selected** button. From the options that appear, select **Software downloads** (on the right-hand side). Download the “USB Console Port Drivers and Information.”

---

## Direct console access

To connect a console to the switch, follow these steps:

1. Connect the PC or terminal to the switch's Console Port using the console cable included with the switch. (If your PC or terminal has a 25-pin serial connector, first attach a 9-pin to 25-pin straight-through adapter at one end of the console cable.)

Alternatively, connect the PC to the switch's Micro USB Console Port using a USB cable (not supplied). Use a USB 2.0 high-speed cable with male type A (4-pin) to male micro-B (5-pin) connectors. The maximum allowable length is 5 meters.



To use the USB Console Port, you must first download a USB driver to the PC. See the Note on [page 24](#) for more information.

**Figure 13 Connecting a console cable**

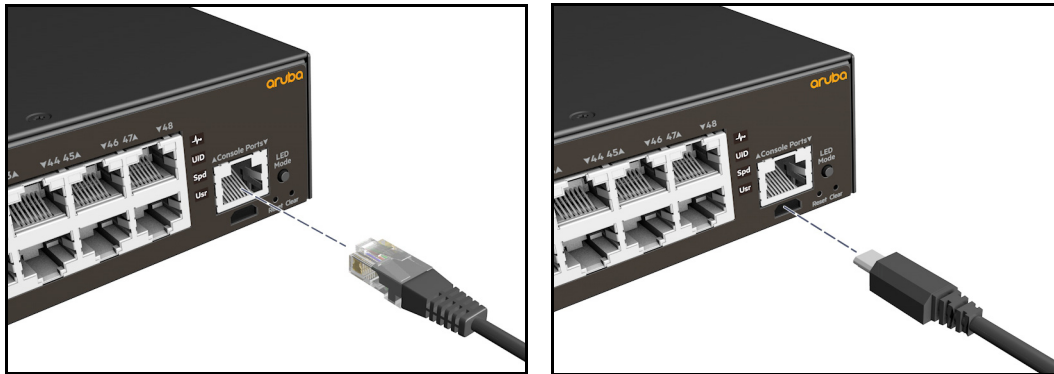

2. Turn on the terminal or PC's power and, if using a PC, start the PC terminal program.
3. Press **[Enter]** two or three times and you will see the copyright page and the message "Press any key to continue". Press a key, and you will then see the switch console command (CLI) prompt, for example:

```
Aruba-2540-24G-4SFPP#
```

If you want to continue with console management of the switch at this time, see chapter 3, "[Getting started with switch configuration](#)" ([page 30](#)) for some basic configuration steps. For more detailed information, refer to the *Basic Operation Guide* and the *Management and Configuration Guide*, which are on the Hewlett Packard Enterprise Web site at [www.hpe.com/networking/ResourceCenter](http://www.hpe.com/networking/ResourceCenter).

## Console cable pinouts

The console cable has an RJ-45 plug on one end and a DB-9 female connector on the other end. [Table 10 \(page 25\)](#) describes the mapping of the RJ-45 to DB-9 pins.

**Figure 14 RJ-45 to DB-9 pinouts**



**Table 10 Mapping of RJ-45 to DB-9**

RJ-45 (Signal reference from Chassis)		DB-9 (Signal reference from PC)	
Reserved	1	8	CTS
Reserved	2	6	DSR
TXD	3	2	RXD
Reserved	4	1	DCD
GND	5	5	GND
RXD	6	3	TXD
Reserved	7	4	DTR

**Table 10 Mapping of RJ-45 to DB-9 (Continued)**

RJ-45 (Signal reference from Chassis)		DB-9 (Signal reference from PC)	
Reserved	8	7	RTS
		9	RI

## 7. Connect the network cables

Connect the network cables, described under “Cabling Infrastructure” (“[1. Prepare the installation site](#)” (page 17)), from the network devices or your patch panels to the fixed RJ-45 ports on the switch or to any SFPs you have installed in the switch.

### Using the RJ-45 connectors

To connect:

Push the RJ-45 plug into the RJ-45 port until the tab on the plug clicks into place. When power is on for the switch and for the connected device, the Link LED for the port should light to confirm a powered-on device (for example, an end node) is at the other end of the cable.

If the Link LED does *not* go on when the network cable is connected to the port, see “[Diagnosing with the LEDs](#)” (page 35) in chapter 4, “Troubleshooting”.

To disconnect:

Press the small tab on the plug and pull the plug out of the port.

**Figure 15 Connecting an RJ-45**

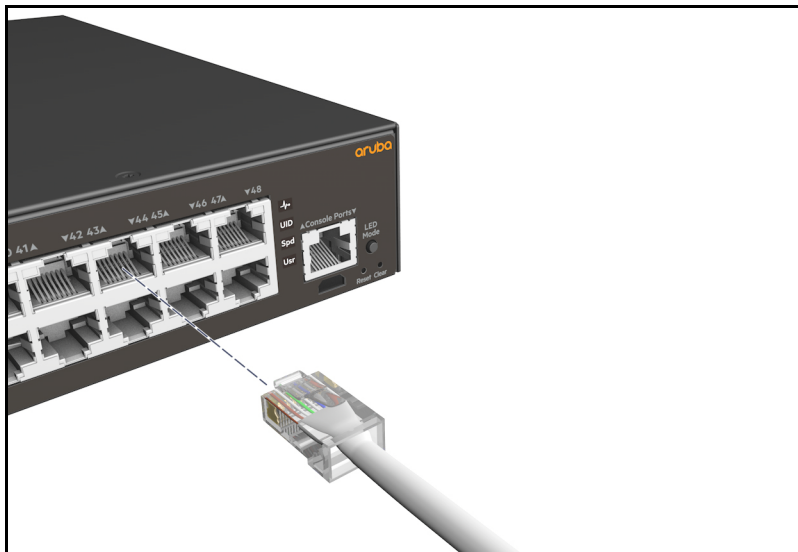

### Connecting cables to SFP/SFP+ transceivers

If you have any transceivers installed in the switch, the type of network connections you will need to use depends on the type of transceivers installed. See chapter 6, “[Cabling and technology information](#)” (page 43), for cabling information.

For transceiver ports, and in general for all the switch ports, a network cable from an active network device is connected to the port. If the port LED does not come on half-bright when the network cable is connected to the port, see “[Diagnosing with the LEDs](#)” (page 35) in chapter 4, “Troubleshooting.”

**Figure 16 Connecting cable to a transceiver**

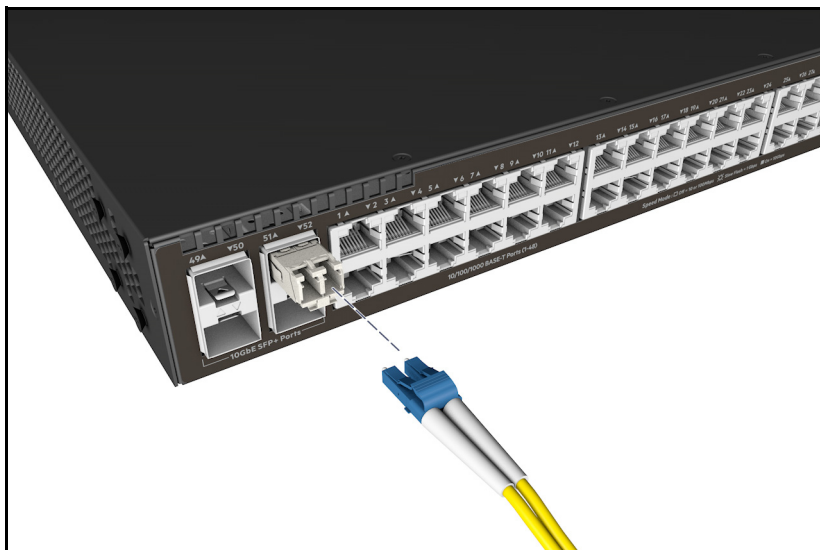

## Sample network topologies

This section shows a few sample network topologies in which the Aruba 2540 switches are implemented. For more topology information, visit the product's website at [www.hpe.com/networking/support](http://www.hpe.com/networking/support).

### As a desktop switch implementing PoE

The switch is designed to be used primarily as a desktop switch to which end nodes, printers and other peripherals, and servers are directly connected, as shown in the following illustration.

Notice that the end node devices are connected to the switch by straight-through or crossover twisted-pair cables. Either cable type can be used because of the "IEEE Auto MDI/MDI-X" features on the switch.

**Figure 17 Basic desktop configuration**

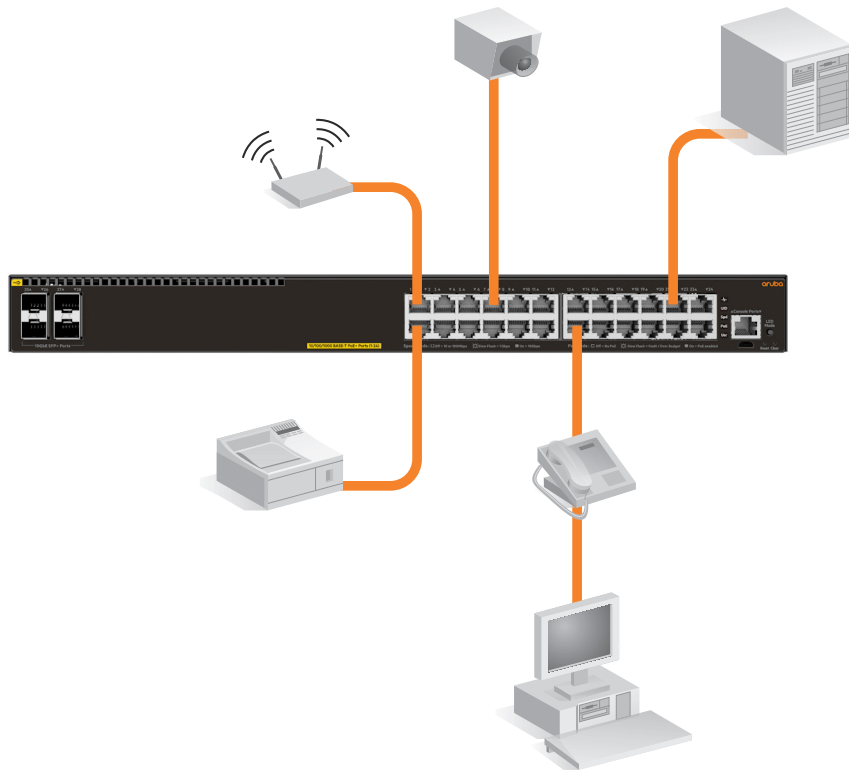

The above illustration is an example of the switch being configured to supply PoE/PoE+ power to end devices such as IP telephones and wireless access points (WAPs).

As shown in [Figure 17 \(page 28\)](#), the IP telephones can be connected in line, that is, between the switch and the end device, in this case a PC. The IP telephones have two ports, one in and one out. Therefore the phone receives voice and power from the switch and the PC can send and receive data through the phone to the switch.

The end node devices are connected to the switch by straight-through or crossover twisted-pair cables. Either cable type can be used because of the Auto-MDIX feature on the switch.

## As a segment switch implementing PoE

**Figure 18 Segment network configuration with PoE switches**

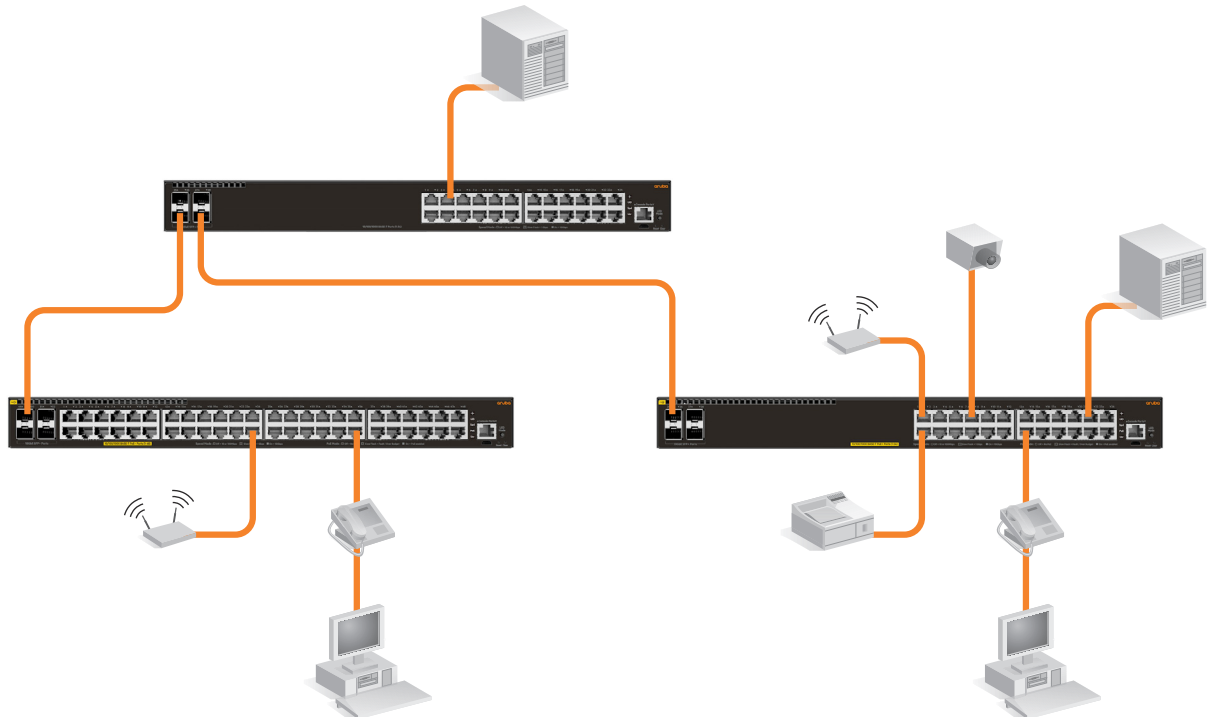

The Aruba 2540 switch also works well as a segment switch. That is, with its high performance, it can be used for interconnecting network segments—simply connect the network devices that form those segments to the switch, or you can also connect other switches.

In the illustration above, two 2540 PoE+ switches with PCs, printers, and local servers attached, are both connected to a non-PoE switch. The devices attached to the two 2540 PoE+ switches can now communicate with each other through the non-PoE switch. They can also all communicate with the server that is connected to a 1000BASE-T port on the switch.

As shown in the illustration above, the IP telephones have been inserted in between the 2540 PoE+ switch and the PCs, and a wireless access point (WAP) has been connected to the 2540 PoE+ switch. Only devices directly connected to PoE switches can receive PoE power. Devices connected to the non-PoE switch cannot receive PoE power.

Because the 2540 switches have the Auto-MDIX feature, the connections between the switches and end nodes or servers can be through category 5 straight-through or crossover twisted-pair cable. Category 3 or 4 cable can also be used if the connection is 10 Mbps only. In all cases, the device ports must be configured to auto negotiate the link characteristics for this feature to work.

The switch, in turn, can be connected to a network backbone through fiber-optic cabling connected to a Gigabit or 10 Gigabit transceiver installed in the switch. Now, all the devices on these network segments can access other network resources that are connected elsewhere on the network backbone.

# 3 Getting started with switch configuration

This chapter is a guide for using the console Switch Setup screen to quickly assign an IP (Internet Protocol) address and subnet mask to the switch, set a Manager password, and, optionally, configure other basic features.

For more information on using the switch console, see the *Basic Operation Guide* and the *Management and Configuration Guide* for your switch at [www.hpe.com/networking/ResourceCenter](http://www.hpe.com/networking/ResourceCenter). For information on the HPE IMC (Intelligent Management Center), contact your HPE/Aruba representative. For information on Aruba AirWave, go to [www.arubanetworks.com/products/networking/management/airwave](http://www.arubanetworks.com/products/networking/management/airwave).

## Recommended minimal configuration

In the factory default configuration, the switch has no IP (Internet Protocol) address and subnet mask, and no passwords. In this state, it can be managed only through a direct console connection. To manage the switch through in-band (networked) access, you should configure the switch with an IP address and subnet mask compatible with your network.

Also, you should configure a Manager password to control access privileges from the console and Web browser interface. Other parameters in the Switch Setup screen can be left at their default settings or you can configure them with values you enter.

Many other features can be configured through the switch's console interface, to optimize the switch's performance, to enhance your control of the network traffic, and to improve network security. Once an IP address has been configured on the switch, these features can be accessed more conveniently through a remote Telnet session, through the switch's Web browser interface, and from an SNMP network management station running a network management program. For a listing of switch features available with and without an IP address, refer to "How IP Addressing Affects Switch Operation" in the *Management and Configuration Guide*.

For more information on IP addressing, refer to the *Basic Operation Guide* at [www.hpe.com/networking/ResourceCenter](http://www.hpe.com/networking/ResourceCenter).

---

**NOTE:** By default, the switch is configured to acquire an IP address configuration from a DHCP or Bootp server. To use DHCP/Bootp instead of the manual method described in this chapter, see "DHCP/Bootp Operation" in the *Management and Configuration Guide*.

---

## Using the console setup screen

The quickest and easiest way to minimally configure the switch for management and password protection in your network is to use a direct console connection to the switch, start a console session, and access the Switch Setup screen.

1. Using the method described in "[Terminal configuration](#)" (page 24), connect a terminal device to the switch and display the switch console command line interface (CLI) prompt (the default display).

The CLI prompt appears, for example:

```
Aruba-2540-24G-4SFPP#
```

2. At the prompt, enter the **setup** command to display the Switch Setup screen. The following illustration shows the Setup screen with the default settings.

**Figure 19 Example console setup screen**

```

Aruba-2540-24G-PoEP-4SFPP                               6-Aug-2016    8:23:16
=====-- CONSOLE - MANAGER MODE -----
                          Switch Setup

System Name : Aruba-2540-24G-4SFPP
System Contact :
Manager Password : *****
Confirm Password : *****
Logon Default : CLI                               Time Zone [0] : 0
Community Name : public
Spanning Tree Enabled [No] : No                   Default Gateway :
Time Sync Method [TIMEP/SNTP] : TIMEP/SNTP
TIMEP Mode [Disabled] : Disabled

IP Config [Manual] : DHCP/Bootp

IP Address   : 15.255.133.94
Subnet Mask  : 255.255.248.0
Actions->   Cancel      Edit      Save      Help

Enter System Name - up to 32 characters.
Use arrow keys to change field selection, <Space> to toggle field choices,
and <Enter> to go to Actions.

```

1. Use the **Tab** key to select the **Manager Password** field and enter a manager password of up to 16 printable ASCII characters.
2. **Tab** to the **IP Config (DHCP/Bootp)** field and use the Space bar to select the **Manual** option.
3. **Tab** to the **IP Address** field and enter the IP address that is compatible with your network.
4. **Tab** to the **Subnet Mask** field and enter the subnet mask used for your network.
5. Press **Enter**, then **S** (for **Save**).

The following fields are displayed in the Setup screen. For more information on these fields, see the *Management and Configuration Guide*:

**Table 11 Default parameters**

Parameter	Default	
System Name	<i>model name</i>	Optional; up to 25 characters, including spaces
System Contact	blank	Optional; up to 48 characters, including spaces
Manager Password	blank	Recommended; up to 64 characters (no blank spaces)
Logon Default	CLI	The default setting selects the command line interface for console access. The alternative is the menu interface.
Time Zone	0 (none)	Optional; 1440 to -1440. The number of minutes your location is to the West (-) or East (+) of GMT.
Community Name	public	Default setting recommended.
Spanning Tree Enabled	No	Default setting recommended unless STP is already running on your network or the switch will be used in complex network topologies.
Default Gateway	blank	Optional; Enter the IP address of the next-hop gateway node if network traffic needs to be able to reach off-subnet destinations.
Time Sync Method	None	Optional; The protocol the switch uses to acquire a time signal. The options are NTP, SNTP, TimeP, and TimeP/SNTP.
TimeP Mode	Disabled	Optional; The method the switch uses to acquire the TimeP server address.

**Table 11 Default parameters** *(continued)*

Parameter	Default	
IP Config (DHCP/Bootp)	DHCP/Bootp	Set to Manual unless a DHCP/Bootp server is used on your network to configure IP addressing.
IP Address	xxx.xxx.xxx.xxx	Recommended; If you set IP Config to Manual, then enter an IP address compatible with your network.
<b>Note:</b> The IP address and subnet mask assigned for the switch must be compatible with the IP addressing used in your network. For more information on IP addressing, see the <i>Management and Configuration Guide</i> .		
Subnet Mask	xxx.xxx.xxx.xxx	Recommended; If you entered an IP address, then enter a subnet mask compatible with your network.

## Where to go from here

The above procedure configures your switch with a Manager password, IP address, and subnet mask. As a result, with the proper network connections, you can now manage the switch from a PC equipped with Telnet, and/or a web browser interface.

Some basic information on managing your switch is included in the next section. For more information on the console, web browser, and SNMP management interfaces and all the features that can be configured on the switch, see the *Basic Operation Guide* and the *Management and Configuration Guide* at [www.hpe.com/networking/ResourceCenter](http://www.hpe.com/networking/ResourceCenter).

## Software updates

See “[Accessing updates](#)” (page 49).

## To recover from a lost manager password:

If you cannot start a console session at the manager level because of a lost Manager password, you can clear all passwords and user names by getting physical access to the switch and pressing and holding the Clear button for more than 5 seconds. See “[Reset and Clear buttons](#)” (page 12).

## Using the IP address for remote switch management

The switch’s IP address can be used to manage the switch from any PC on the same or on a different subnet as the switch. In a networked connection, you can use a Telnet session or a standard web browser to manage the switch.

## Starting a Telnet session

To access the switch through a Telnet session, follow these steps:

1. Make sure the switch is configured with an IP address and that the switch is reachable from the PC that is running the Telnet session (for example, by using a Ping command to the switch’s IP address).
2. Start the Telnet program on a PC that is on the same subnet as the switch and connect to the switch’s IP address.
3. You will see the copyright page and the message “Press any key to continue”. Press a key, and you will then see the switch console command (CLI) prompt, for example:

```
Aruba-2540-24G-4SFPP#
```

Enter **help** or **?** to see a list of commands that can be executed at the prompt. Entering any command followed by **help** provides more detailed context help information about the command. Entering any command followed by **?** displays a list of options that are available at that point in the command entry.



## Starting a web browser session

The Aruba 2540 switches can be managed through a graphical interface that you can access from any PC or workstation on the network by running your web browser and typing in the switch's IP address as the URL. No additional software installation is required to make this interface available; it is included in the switch's onboard software.

The following illustration shows a typical web browser interface screen.

**Figure 20 Web browser interface screen**

The screenshot displays the Aruba web browser interface for an Aruba 2540-24G-4SFPP switch. The interface is organized into several panels:

- Switch Status:** Displays system information such as System Name (Aruba-2540-24G-4SFPP), System Location, System Contact, System Uptime (3 minutes, 35 seconds), System CPU Util (7%), and System Memory (355660288 Bytes).
- Unit Information:** Displays product details including Product Name (Aruba 2540-24G-4SFPP+ Switch (JL3545)), IP Address (192.168.1.5), Base MAC Address (94 18 62 55 10 20), Serial Number (C162ZYH002), Mgmt Server (http://1917007.www1.hp.com/device\_help), and Version (YC.16.02.0011, ROM YC.16.01.0001).
- Basic VLAN Information:** Shows Total VLANs (1) and a table for the Primary VLAN (ID 1, Name DEFAULT\_VLAN, Status Port-based, IP Address 192.168.1.5).
- Alert Log:** Provides a filter by Date/Time and a table of alerts, including one for 'First time installation' on Mon Jan 1 00:00:17 1990.
- Device View:** Shows Port Status (28) and a visual representation of the switch's ports and fan status.
- Details:** Provides a comprehensive table of port statistics for Port Name 1, including Enabled status (Up), Type (100/1000T), and various utilization and error metrics.

Totals:		Receive	Transmit
Enabled:	Up	Bytes: 98743	1040024
Type:	100/1000T	Unicast: 767	716
		Bcast/Mcast: 297	8

Utilization:		Receive	Transmit	Errors:	Receive	Transmit
Total (Drops):	0	0	0	FCS:	0	0
Unicast (pps):	0	0	0	Alignment:	0	0
B/Mcast (pps):	0	0	0	Runts:	0	0
Utilization%:	0	0	0	Giants:	0	0
				Total Errors:	0	0
				Drops:	0	0
				Collisions:	0	0
Recv Discards:	0			Late Collins:	0	0
Unknown Protos:	0			Excess Collins:	0	0
Out Queue Len:	0			Deferred:	0	0

An extensive help system is also available for the web browser interface. To access the help system, the subnet on which the switch is installed must have access to the Internet, or IMC needs to be installed on a network management station that is on the subnet.

## 4 Troubleshooting

This chapter describes how to troubleshoot your switch. This document describes troubleshooting mostly from a hardware perspective. You can perform more in-depth troubleshooting on these devices using the software tools available with the switches, including the full-featured console interface, the built-in web browser interface, and IMC, the SNMP-based network management tool, or Aruba AirWave. For more information, see the chapter “Troubleshooting” in the *Management and Configuration Guide*, which is on the Hewlett Packard Enterprise website at [www.hpe.com/networking/ResourceCenter](http://www.hpe.com/networking/ResourceCenter).

This chapter describes the following:

- Basic troubleshooting tips (see “[Basic troubleshooting tips](#)” (page 34))
- Diagnosing with the LEDs (see “[Diagnosing with the LEDs](#)” (page 35))
- Proactive networking tools (see “[Proactive networking](#)” (page 38))
- Hardware diagnostic tests (see “[Hardware diagnostic tests](#)” (page 38))
- Restoring the factory default configuration (see “[Restoring the factory default configuration](#)” (page 39))
- Downloading new software to the Aruba 2540 switches (see “[Downloading new switch software](#)” (page 40))
- Hewlett Packard Enterprise Customer Support Services (see “[Hewlett Packard Enterprise Customer Support Services](#)” (page 40))

### Basic troubleshooting tips

Most problems are caused by the following situations. Check for these items first when starting your troubleshooting:

- **Connecting to devices that have a fixed full-duplex configuration.** The RJ-45 ports are configured as “Auto”. That is, when connecting to attached devices, the switch operates in one of two ways to determine the link speed and the communication mode (half duplex or full duplex):
  - If the connected device is also configured to Auto, the switch will automatically negotiate both link speed and communication mode.
  - If the connected device has a fixed configuration, for example 100 Mbps, at half or full duplex, the switch will automatically sense the link speed, but will default to a communication mode of half duplex.



---

**CAUTION!** Because the switch behaves in this way (*in compliance with the IEEE 802.3 standard*), if a device connected to the switch has a fixed configuration at full duplex, the device will not connect correctly to the switch. The result will be high error rates and very inefficient communications between the switch and the device.

Ensure all devices connected to the switch are configured to auto negotiate, or are configured to speed and duplex settings matching those configured on the corresponding switch port.

- 
- **Faulty or loose cables.** Look for loose or obviously faulty connections. If the cables appear to be OK, make sure the connections are snug. If that does not correct the problem, try a different cable.
  - **Non-standard cables.** Non-standard and miswired cables may cause network collisions and other network problems, and can seriously impair network performance. Use a new correctly-wired cable or compare your cable to the cable in chapter 6, “[Cabling and technology](#)”

information” (page 43) for pinouts and correct cable wiring. A category 5 cable tester is a recommended tool for every 100BASE-TX and 1000BASE-T network installation.

- **Improper network topologies.** It is important to make sure you have a valid network topology. Common topology faults include excessive cable length and excessive repeater delays between end nodes. If you have network problems after recent changes to the network, change back to the previous topology. If you no longer experience the problems, the new topology is probably at fault. Sample topologies are shown at the end of chapter 2 in this book.

In addition, you should make sure that your network topology contains **no data path loops**. Between any two end nodes, there should be only one active cabling path at any time. Data path loops can cause broadcast storms that will severely impact your network performance.

For your switch, if you want to build redundant paths between important nodes in your network to provide some fault tolerance, you should enable **Spanning Tree Protocol** support on the switch. This ensures that only one of the redundant paths is active at any time, thus avoiding data path loops. Spanning Tree can be enabled through the switch console or the web browser interface. For more information on Spanning Tree, see the *Advanced Traffic Management Guide* for your switch at [www.hpe.com/networking/ResourceCenter](http://www.hpe.com/networking/ResourceCenter).

The switch also supports **Trunking**, which allows multiple network cables to be used for a single network connection without causing a data path loop. For more information on Trunking, see the *Management and Configuration Guide*, which is on the Hewlett Packard Enterprise website at [www.hpe.com/networking/ResourceCenter](http://www.hpe.com/networking/ResourceCenter).

- **Check the port configuration.** A port on your switch may not be operating as expected because it is administratively disabled in the configuration. It may also be placed into a “blocking” state by a protocol operating on the port (dynamic VLANs), or LACP (dynamic trunking). For example, the normal operation of the Spanning Tree, GVRP, LACP, and other features may put the port in a blocking state.

Use the switch console to determine the port’s configuration and verify that there is not an improper or undesired configuration of any of the switch features that may be affecting the port. For more information, see the *Management and Configuration Guide* for your switch at [www.hpe.com/networking/ResourceCenter](http://www.hpe.com/networking/ResourceCenter).

## Diagnosing with the LEDs

Table 12 (page 35) shows LED patterns on the switch that indicate problem conditions for general switch operation troubleshooting.

Table 13 (page 38) shows LED patterns that indicate problem conditions for PoE troubleshooting.

### LED patterns for general switch troubleshooting

1. Check in the table for the LED pattern you see on your switch.
2. Refer to the corresponding diagnostic tip on the next few pages.

**Table 12 LED error indicators**

LED Pattern Indicating Problems		Diagnostic Tip
Global Status	Port LED	
Off with power cord plugged in		1
Solid orange		2
Slow flash orange		3
Slow flash orange	Slow Flash Orange <sup>1</sup>	4
Solid green	Off with cable connected	5

**Table 12 LED error indicators (continued)**

LED Pattern Indicating Problems		Diagnostic Tip
Global Status	Port LED	
Solid green	On, but the port is not communicating	6
<sup>1</sup> The flashing behavior is an on/off cycle once every 1.6 seconds, approximately.		

Diagnostic tips:

Tip	Problem	Solution
1	The switch is not plugged into an active AC power source, or the switch's power supply may have failed.	<p>Verify the power cord is plugged into an active power source and to the switch. Make sure these connections are snug.</p> <p>Try power cycling the switch by unplugging and plugging the power cord back in.</p> <p>If the Global Status LED is still not on, verify the AC power source works by plugging another device into the outlet. Or try plugging the switch into a different outlet or try a different power cord.</p> <p>If the power source and power cord are OK and this condition persists, the switch power supply may have failed. Call your Hewlett Packard Enterprise-authorized network reseller, or use the electronic support services from Hewlett Packard Enterprise to get assistance.</p>
2	A switch hardware failure has occurred. All the LEDs will stay on indefinitely.	<p>Try power cycling the switch. If the fault indication reoccurs, the switch may have failed. Call your Hewlett Packard Enterprise-authorized network reseller, or use the electronic support services from Hewlett Packard Enterprise to get assistance.</p>
3	The switch has experienced a software failure during self test, or one of the switch cooling fans may have failed.	<p>Try resetting the switch by pressing the Reset button on the front of the switch, or by power cycling the switch.</p> <p>If the fault indication reoccurs, attach a console to the switch (as indicated in chapter 2) and configure it to operate at 9600 baud. Then, reset the switch. Messages should appear on the console screen and in the console log identifying the error condition. You can view the console log at that point by selecting it from the console Main Menu or by typing "Show log" at the Manager command prompt (#).</p> <p>The error may indicate that one of the fans has failed. In switches with multiple fans the switch may continue to operate under this condition if the ambient temperature does not exceed normal room temperature, but for best operation, the switch should be replaced.</p> <p>If necessary to resolve the problem, contact your Hewlett Packard Enterprise-authorized network reseller, or use the electronic support services from Hewlett Packard Enterprise to get assistance.</p>
4	The network port for which the LED is flashing has experienced a self test or initialization failure.	<p>Try power cycling the switch. If the fault indication reoccurs, the switch port may have failed. Call your Hewlett Packard Enterprise-authorized network reseller, or use the electronic support services from Hewlett Packard Enterprise to get assistance.</p> <p>If the port is an SFP, verify that it is one of the SFPs supported by the switch. Unsupported SFPs will be identified with this fault condition. The supported SFPs are listed in Chapter 1, "Introducing the 2540 switches" (page 6). The SFPs are also tested when they are "hot-swapped"—installed or changed while the switch is powered on.</p> <p>To verify the port has failed, remove and reinstall the SFP without powering off the switch. If the port fault indication reoccurs, you will have to replace the SFP. Check the event log to see why the SFP failed.</p>

Tip	Problem	Solution
5	The network connection is not working properly.	<p>Try the following procedures:</p> <p>For the indicated port, verify that both ends of the cabling, at the switch and the connected device, are connected properly.</p> <p>Verify the connected device and switch are both powered <i>on</i> and operating correctly.</p> <p>Verify you have used the correct cable type for the connection:</p> <p>For twisted-pair connections to the fixed 10/100/1000 ports, if the port is configured to “Auto” (auto negotiate), either straight-through or crossover cables can be used because of the switch’s “Auto-MDIX” feature and the Auto MDI/MDI-X feature of the 10/100/1000-T port.</p> <p><b>Note:</b> If the switch port configuration is changed to one of the <b>fixed configuration</b> options (for example, 100 Mbps/Full Duplex), then the port operates as <b>MDI-X only</b> and you must use the correct type of cable for the connection. In general, for connecting an end node (MDI port) to the switch, use straight-through cable; for connecting to MDI-X ports on hubs, other switches, and routers, use crossover cable.</p> <p>For fiber-optic connections, verify the transmit port on the switch is connected to the receive port on the connected device, and the switch receive port is connected to the transmit port on the connected device.</p> <p>For 1000BASE-T connections, verify the network cabling complies with the IEEE 802.3ab standard. The cable should be installed according to the ANSI/TIA/EIA-568-A-5 specifications. Cable testing should comply with the stated limitations for Attenuation, Near-End Crosstalk, Far-End Crosstalk, Equal-Level Far-End Crosstalk (ELFEXT), Multiple Disturber ELFEXT, and Return Loss.</p> <p>The cable verification process must include all patch cables from any end devices, including the switch, to any patch panels in the cabling path.</p> <p>Verify the port has not been disabled through a switch configuration change. You can use the console interface, or, if you have configured an IP address on the switch, use the Web browser interface to determine the state of the port and re-enable the port if necessary.</p> <p>Verify the switch port configuration matches the configuration of the attached device. For example, if the switch port is configured as “Auto”, the port on the attached device also <b>MUST</b> be configured as “Auto”. Depending on the port type, twisted-pair or fiber-optic, if the configurations don’t match, the results could be a very unreliable connection, or no link at all.</p> <p>If the other procedures don’t resolve the problem, try using a different port or a different cable.</p>
6	The port may be improperly configured, or the port may be in a “blocking” state by the normal operation of the Spanning Tree, LACP, or IGMP features.	<p>Use the switch console to see if the port is part of a dynamic trunk (through the LACP feature) or to see if Spanning Tree is enabled on the switch, and to see if the port may have been put into a “blocking” state by those features. The <b>show lacp</b> command displays the port status for the LACP feature; the <b>show spanning-tree</b> command displays the port status for Spanning Tree.</p> <p>Also check the Port Status screen using the <b>show interfaces</b> command to see if the port has been configured as “disabled”.</p> <p>Other switch features that may affect the port operation include VLANs and IGMP. Use the switch console to see how the port is configured for these features.</p> <p>For software troubleshooting tips, see the chapter “Troubleshooting” in the <i>Management and Configuration Guide</i>, which is on the Hewlett Packard Enterprise website at <a href="http://www.hpe.com/networking/ResourceCenter">www.hpe.com/networking/ResourceCenter</a>.</p> <p>Ensure also, that the device at the other end of the connection is indicating a good link to the switch. If it is not, the problem may be with the cabling between the devices or the connectors on the cable.</p>

## LED patterns for PoE troubleshooting

If the PoE Status LED is flashing, that indicates a problem with the delivery of PoE power out one or more switch ports. Press the LED Mode button to put the switch into PoE mode and the port LEDs will show which ports are experiencing the problem. The following tables identify the specific problems that are shown by the LEDs.

1. Check in the table for the LED pattern you see on your switch.
2. Refer to the corresponding diagnostic tip.

**Table 13 LED error indicators for PoE**

LED Pattern Indicating Problems		Diagnostic Tips
Global Status	Port LED (PoE mode)	
Solid green	Fast Flash Orange	1
Slow flash orange	Slow Flash Orange	2

Diagnostic Tips:

Tip	Problem	Solution
1	PoE oversubscription condition. All available PoE power is already taken by higher-priority ports. The port may be detecting an external PD fault.	If possible, redefine port priorities. Also, check the external PD for a fault.
2	PoE hardware fault. A switch hardware component that is involved with PoE power delivery has failed.	Check the port for a hardware failure, this may require a reboot of the switch. If a hardware failure is confirmed, replace the switch.

## Proactive networking

The Aruba 2540 switch has built-in management capabilities that proactively help you manage your network including:

- finding and helping you fix the most common network error conditions (for example, faulty network cabling, and non-standard network topologies)
- informing you of the problem with clear, easy-to-understand messages
- recommending network configuration changes to enhance the performance of your network

The following interfaces and management tools provide tests, indicators, and an event log that can be used to monitor the switch and its network connections and to help you take advantage of these proactive networking features:

- Aruba AirWave—A powerful and easy-to-use network operations system that manages wired and wireless infrastructures. For more information, go to [www.arubanetworks.com/products/networking/management/airwave](http://www.arubanetworks.com/products/networking/management/airwave).
- IMC (Intelligent Management Center)—an SNMP-based network management tool. Free trials of IMC can be downloaded at <http://www.hpe.com/networking/imc>.
- A graphical web browser interface you can use to manage your switch from a PC running a supported web browser, for example Microsoft Internet Explorer.
- A full-featured easy-to-use console interface you can access by connecting a standard terminal or PC running a terminal emulator to the switch's console port. The cable to make that connection is provided with your switch. The console interface is also accessible through a Telnet connection.

## Hardware diagnostic tests

### Testing the switch by resetting it

If you believe the switch is not operating correctly, you can reset the switch to test its circuitry and operating code. To reset a switch, either:

- unplug and plug in the power cord (power cycling)
- press the Reset button on the front of the switch



- reboot the switch via the management console's **boot system** command.

Power cycling the switch and pressing the Reset button both cause the switch to perform its power-on self test. These reset processes also cause any network traffic counters to be reset to zero, and cause the System Up Time timer to reset to zero.

## Checking the switch LEDs

See “[Diagnosing with the LEDs](#)” (page 35) for information on interpreting the LED patterns.

## Checking console messages

Useful diagnostic messages may be displayed on the console screen when the switch is reset. As described in chapter 2 under step 6, connect a PC running a VT-100 terminal emulator program or a standard VT-100 terminal to the switch's Console Port and configure it to run at 9600 baud, and with the other terminal communication settings shown on “[Terminal configuration](#)” (page 24). Then, when you reset the switch, note the messages that are displayed. Additionally, you can check the switch event log, which can be accessed from the console using the **show log** command, or from the console Main Menu.

## Testing twisted-pair cabling

Network cables that fail to provide a link or provide an unreliable link between the switch and the connected network device may not be compatible with the IEEE 802.3 Type 10BASE-T, 100BASE-TX, or 1000BASE-T standards. The twisted-pair cables attached to the switch must be compatible with the appropriate standards. To verify your cable is compatible with these standards, use a qualified cable test device.

## Testing switch-to-device network communications

You can perform the following communication tests to verify the network is operating correctly between the switch and any connected device that can respond correctly to the communication test.

- **Link Test**—a physical layer test that sends IEEE 802.2 test packets to any device identified by its MAC address
- **Ping Test**—a network layer test used on IP networks that sends test packets to any device identified by its IP address

These tests can be performed through the switch console interface from a terminal connected to the switch or through a Telnet connection, or from the switch's web browser interface. For more information, see the *Basic Operation Guide*, which is on the Hewlett Packard Enterprise website at [www.hpe.com/networking/ResourceCenter](http://www.hpe.com/networking/ResourceCenter).

## Testing end-to-end network communications

Both the switch and the cabling can be tested by running an end-to-end communications test—a test that sends known data from one network device to another through the switch. For example, if you have two PCs on the network that have LAN adapters between which you can run a link-level test or Ping test through the switch, you can use this test to verify that the entire communication path between the two PCs is functioning correctly. See your LAN adapter documentation for more information on running a link test or Ping test.

## Restoring the factory default configuration

As part of your troubleshooting process on the switch, it may become necessary to return the switch configuration to the factory default settings. This clears any passwords, clears the console

event log, resets the network counters to zero, performs a complete self test, and reboots the switch into its factory default configuration including deleting the IP address, if one is configured.

---

**NOTE:** This process removes all switch configuration changes that you have made from the factory default settings. This includes, for example, configuration of VLANs, Spanning Tree, and trunks. Returning the configuration of these features to their factory default settings (usually disabling them) may result in network connectivity issues.

If the switch has a valid configuration, and you are restoring the factory default settings for a reason other than configuration problems, you should save the switch configuration prior to performing the factory default reset. Then, after the reset and resolution of the original problem, you can restore the saved configuration to the switch.

---

You can restore the factory default configuration either on the switch itself, or through the switch console.

To execute the factory default reset on the switch, perform these steps:

1. Using pointed objects, simultaneously press both the Reset and Clear buttons on the front of the switch.
2. Continue to press the Clear button while releasing the Reset button.
3. When the Global Status LED begins to fast flash orange (after approximately 5 seconds), release the Clear button.

The switch will then complete its self test and begin operating with its configuration restored to the factory default settings.

To restore the factory default configuration using the console, execute the **erase startup-config** command from the console command prompt.

## Downloading new switch software

Software Updates can be downloaded to the switch through several methods. See [“Accessing updates” \(page 49\)](#).

## Hewlett Packard Enterprise Customer Support Services

If you are still having trouble with your product, see [“Support and other resources” \(page 49\)](#).



# 5 Specifications

## Switch specifications

### Physical

Product	Width	Depth	Height	Weight
Aruba 2540 24G 4SFP+ Switch (JL354A)	442.5 mm (17.42 in)	200 cm (7.87 in)	43.95 mm (1.73 in)	2.39 kg (5.26 lb)
Aruba 2540 48G 4SFP+ Switch (JL355A)	442.5 mm (17.42 in)	246 cm (9.69 in)	43.95 mm (1.73 in)	3.12 kg (6.88 lb)
Aruba 2540 24G PoE+ 4SFP+ Switch (JL356A)	442.5 mm (17.42 in)	304 cm (11.97 in)	43.95 mm (1.73 in)	4.05 kg (8.93 lb)
Aruba 2540 48G PoE+ 4SFP+ Switch (JL357A)	442.5 mm (17.42 in)	304 cm (11.97 in)	43.95 mm (1.73 in)	4.45 kg (9.82 lb)

### Electrical

Product	AC Voltage	Maximum current	Frequency range
Aruba 2540 24G 4SFP+ Switch (JL354A) <sup>1</sup>	100-127 volts 200-240 volts	0.6 A 0.4 A	50/60 Hz
Aruba 2540 48G 4SFP+ Switch (JL355A) <sup>1</sup>	100-127 volts 200-240 volts	0.9 A 0.6 A	50/60 Hz
Aruba 2540 24G PoE+ 4SFP+ Switch (JL356A) <sup>1</sup>	100-127 volts 200-240 volts	4.9 A 2.4 A	50/60 Hz
Aruba 2540 48G PoE+ 4SFP+ Switch (JL357A) <sup>1</sup>	100-127 volts 200-240 volts	5.1 A 2.5 A	50/60 Hz

<sup>1</sup> The switch automatically adjusts to any voltage between 100-127 or 200-240 volts and either 50 or 60 Hz.

### Environmental

	Operating	Non-Operating
<b>Temperature</b>	0°C to 45°C (32°F to 113°F) up to 5000 ft 0°C to 40°C (32°F to 104°F) up to 10,000 ft*	-40°C to 70°C (-40°F to 158°F) up to 15,000 ft
<b>Relative humidity (non-condensing)</b>	15% to 95% at 40°C (104°F)	15% to 90% at 65°C (149°F)
<b>Maximum altitude</b>	3.0 Km (10,000 ft)**	4.6 Km (15,000 ft)

\* De-rate -1°C for every 1000 ft from 5000 ft onwards.

\*\* The operating maximum altitude should not exceed that of any accessory being connected to any Aruba 2540 switch.

### Acoustics

Switch Model	Acoustics
Aruba 2540 24G 4SFP+ Switch (JL354A)	Sound Power (LWAd) 5.0 Bel Sound Pressure (LpAm) (Bystander) 37.1 dB
Aruba 2540 48G 4SFP+ Switch (JL355A)	Sound Power (LWAd) 5.4 Bel Sound Pressure (LpAm) (Bystander) 40.2 dB

Aruba 2540 24G PoE+ 4SFP+ Switch (JL356A)	Sound Power (LWAd) 5.4 Bel Sound Pressure (LpAm) (Bystander) 40.6 dB
Aruba 2540 48G PoE+ 4SFP+ Switch (JL357A)	Sound Power (LWAd) 5.6 Bel Sound Pressure (LpAm) (Bystander) 41.7 dB

## Safety

- EN60950-1:2006+A11:2009+A1:2010+A12:2011+A2:2013
- IEC60950-1:2005+Am1:2009 +A2:2013
- CSA22.2 No. 60950-1-07 2nd Ed.; UL60950-1 2nd Ed.
- EN 60825-1:2007 / IEC 60825-1:2007 Class 1

## EMC

- EN 55022:2010, Class A
- EN 55024:2010
- EN 61000-3-2:2014
- EN 61000-3-3:2013
- FCC CFR 47 Part 15B: 2014, Class A
- ICES-003 Issue 6

## Standards

**Table 14 Technology standards and safety compliance**

Technology	Compatible with these IEEE standards	Laser safety information	
		EN/IEC standard compliance	SFP Lasers
<b>10-T</b>	IEEE 802.3 10BASE-T		
<b>100-TX</b>	IEEE 802.3u 100BASE-TX		
<b>1000-T</b>	IEEE 802.3ab 1000BASE-T		
<b>100-FX</b>	IEEE 802.3u 100BASE-FX	EN/IEC 60825	Class 1 Laser Product Laser Klasse 1
<b>1000-SX</b>	IEEE 802.3z 1000BASE-SX	EN/IEC 60825	Class 1 Laser Product Laser Klasse 1
<b>1000-LX</b>	IEEE 802.3z 1000BASE-LX	EN/IEC 60825	Class 1 Laser Product Laser Klasse 1
<b>1000-LH</b>	(not an IEEE standard)	EN/IEC 60825	Class 1 Laser Product Laser Klasse 1
<b>1000-BX</b>	IEEE 802.3ah 1000BASE-BX10	EN/IEC 60825	Class 1 Laser Product Laser Klasse 1

# 6 Cabling and technology information

This appendix includes switch connector information and network cable information for cables that should be used with the Hewlett Packard Enterprise switches.

**NOTE:** Incorrectly wired cabling is a common cause of problems for LAN communications. Hewlett Packard Enterprise recommends that you work with a qualified LAN cable installer for assistance with your cabling requirements.

## Cabling specifications

**Table 15 Cabling specifications**

Twisted-pair copper	10 Mbps Operation	Category 3, 4 or 5, 100-ohm unshielded twisted-pair (UTP) or shielded twisted-pair (STP) cable, complying with IEEE 802.3 10BASE-T specifications.
	100 Mbps Operation	Category 5, 100-ohm UTP or STP cable, complying with IEEE 802.3u 100BASE-TX specifications.
	1000 Mbps Operation	Category 5, 100-ohm 4-pair UTP or STP cable, complying with IEEE 802.3ab 1000BASE-T specifications—Category 5e or better is recommended. See <a href="#">“Note on 1000BASE-T cable requirements” (page 43)</a> .
	10 Gbps Operation	Category 6 or 6A, 100-ohm 4-pair UTP cable, or Category 6A or 7, 100-ohm 4-pair STP cable, complying with IEEE 802.3an 10GBASE-T specifications. See <a href="#">“Technology distance specifications” (page 44)</a> for distances supported with each cable type.
Twinaxial copper	Direct attach cables	One-piece devices consisting of a cable with SFP+ connectors permanently attached to each end, complying with SFF 8431 SFP+ specifications.
Multimode fiber		62.5/125 $\mu\text{m}$ or 50/125 $\mu\text{m}$ (core/cladding) diameter, low metal content, graded index fiber-optic cables, complying with the ITU-T G.651 and ISO/IEC 793-2 Type A1b or A1a standards respectively. <sup>1</sup>
Single mode fiber		9/125 $\mu\text{m}$ (core/cladding) diameter, low metal content fiber-optic cables, complying with the ITU-T G.652 and ISO/IEC 793-2 Type B1 standards.

<sup>1</sup> A mode conditioning patch cord may be needed for some Gigabit-LX installations. See [“Mode conditioning patch cord” \(page 44\)](#) for more information.

### Note on 1000BASE-T cable requirements

The Category 5 networking cables that work for 100BASE-TX connections should also work for 1000BASE-T, as long as all four-pairs are connected. But, for the most robust connections, you should use cabling that complies with the Category 5e specifications, as described in Addendum 5 to the TIA-568-A standard (ANSI/TIA/EIA-568-A-5).

Because of the increased speed provided by 1000BASE-T (Gigabit-T), network cable quality is more important than for either 10BASE-T or 100BASE-TX. Cabling plants being used to carry 1000BASE-T networking must comply with the IEEE 802.3ab standards. In particular, the cabling must pass tests for Attenuation, Near-End Crosstalk (NEXT), and Far-End Crosstalk (FEXT). Additionally, unlike the cables for 100BASE-TX, the 1000BASE-T cables must pass tests for Equal-Level Far-End Crosstalk (ELFEXT) and Return Loss.

When testing your cabling, be sure to include the patch cables that connect the switch and other end devices to the patch panels on your site. The patch cables are frequently overlooked when testing cable and they must also comply with the cabling standards.

# Technology distance specifications

**Table 16 Technology distance specifications**

Technology	Supported cable type	Multimode fiber modal bandwidth	Supported distances
100-FX	multimode fiber	any	up to 2,000 meters
1000-T	twisted-pair copper	N/A	up to 100 meters
1000-SX	multimode fiber	160 MHz*km 200 MHz*km 400 MHz*km 500 MHz*km	2 - 220 meters 2 - 275 meters 2 - 500 meters 2 - 550 meters
1000-LX	multimode fiber single mode fiber	400 MHz*km 500 MHz*km N/A	2 - 550 meters 2 - 550 meters 2 - 10,000 meters
1000-LH	single mode fiber	N/A	10 - 70,000 meters <sup>1</sup>
1000-BX	single mode fiber	N/A	0.5 - 10,000 meters
10-Gig Direct Attach	twinaxial copper	N/A	(various lengths offered)
10-Gig SR	multimode fiber	160 MHz*km 200 MHz*km 400 MHz*km 500 MHz*km 2000 MHz*km	2 - 26 meters 2 - 33 meters 2 - 66 meters 2 - 82 meters 2 - 300 meters
10-Gig LR	single mode fiber	N/A	2 - 10,000 meters
10-Gig ER	single mode fiber	N/A	2 - 40,000 meters

<sup>1</sup> For distances less than 20km, a 10dB attenuator must be used. For distances between 20km and 40km, a 5dB attenuator must be used. Attenuators can be purchased from most cable vendors.

## Mode conditioning patch cord

The following information applies to installations in which multimode fiber-optic cables are connected to a Gigabit-LX port. Multimode cable has a design characteristic called “Differential Mode Delay”, which requires the transmission signals be “conditioned” to compensate for the cable design and thus prevent resulting transmission errors.

Under certain circumstances, depending on the cable used and the lengths of the cable runs, an external Mode Conditioning Patch Cord may need to be installed between the Gigabit-LX transmitting device and the multimode network cable to provide the transmission conditioning. If you experience a high number of transmission errors on those ports, usually CRC or FCS errors, you may need to install one of these patch cords between the fiber-optic port in your switch and your multimode fiber-optic network cabling, at both ends of the network link.

The patch cord consists of a short length of single mode fiber cable coupled to graded-index multimode fiber cable on the transmit side, and only multimode cable on the receive side. The section of single mode fiber is connected in such a way that it minimizes the effects of the differential mode delay in the multimode cable.

---

**NOTE:** Most of the time, if you are using good quality graded-index multimode fiber cable that adheres to the standards listed in this appendix, there should not be a need to use mode conditioning patch cords in your network. This is especially true if the fiber runs in your network are relatively short.

---

## Installing the patch cord

As shown in the illustration below, connect the patch cord to the transceiver with the section of single mode fiber plugged in to the Tx (transmit) port. Then, connect the other end of the patch cord to your network cabling patch panel, or directly to the network multimode fiber.

If you connect the patch cord directly to the network cabling, you may need to install a female-to-female adapter to allow the cables to be connected together.

**Figure 21 Example: Connecting a mode conditioning patch cord for Gigabit-LX**

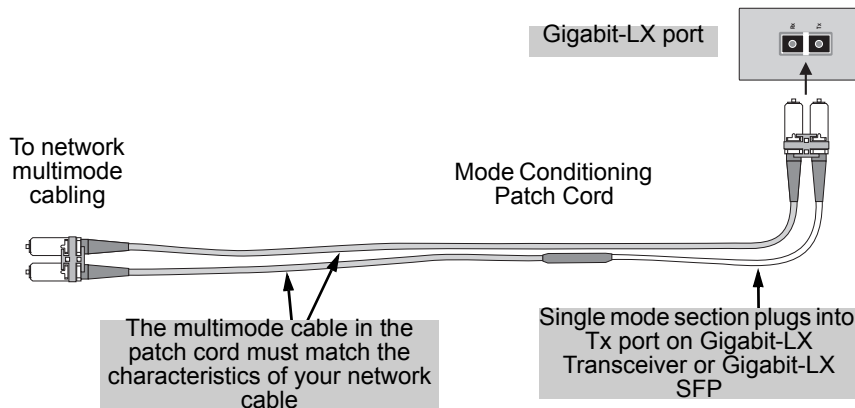

Make sure you purchase a patch cord that has appropriate connectors on each end, and has multimode fibers that match the characteristics of the multimode fiber in your network. Most important, the core diameter of the multimode patch cord must match the core diameter of the multimode cable infrastructure (either 50 or 62.5 microns).

## Twisted-pair cable/connector pinouts

### The Auto-MDIX feature:

In the default configuration, “Auto”, the fixed 10/100/1000BASE-T ports on the Aruba 2540 Switches all automatically detect the type of port on the connected device and operate as either an MDI or MDI-X port, whichever is appropriate. So for any connection, a straight-through twisted-pair cable can be used—you *no longer have to use crossover cables*, although crossover cables can also be used for any of the connections. (The 10/100/1000-T ports support the IEEE 802.3ab standard, which includes the “Auto-MDIX” feature.)

If you connect an Aruba 2540 Switch twisted-pair port to another switch or hub, which typically have MDI-X ports, the Aruba 2540 Switch port automatically operates as an MDI port. If you connect it to an end node, such as a server or PC, which typically have MDI ports, the Aruba 2540 Switch port operates as an MDI-X port. In all cases, you can use standard straight-through cables or crossover cables.

If you happen to use a correctly wired crossover cable, though, the switch will still be able to automatically detect the MDI/MDI-X operation and link correctly to the connected device.

---

### **NOTE: Using fixed configurations.**

If the port configuration is changed to any of the fixed configurations though, for example 100 Mbps/full duplex, the port operates as MDI-X only and the correct cable type must be used: for connections to MDI ports, such as end nodes, use a straight-through cable; for connections to MDI-X ports, such as on hubs and other switches, use a crossover cable.

---

## Other wiring rules:

- All twisted-pair wires used for 10 Mbps, and 100 Mbps operation must be twisted through the entire length of the cable. The wiring sequence must conform to EIA/TIA 568-B (not USOC). See “Twisted-Pair Cable Pin Assignments” later in this appendix for a listing of the signals used on each pin.
- For 1000BASE-T connections, all four pairs of wires in the cable must be available for data transmission.
- For 10 Mbps connections to the ports, you can use Category 3, 4, or 5 unshielded twisted-pair cable, as supported by the IEEE 802.3 Type 10Base-T standard.
- For 100 Mbps connections to the ports, use 100-ohm Category 5 UTP or STP cable only, as supported by the IEEE 802.3u Type 100BASE-TX standard.
- For 1000 Mbps connections, 100-ohm Category 5e or better cabling is recommended.
- To provide Power over Ethernet to the access point, all 4 pairs must be connected for any network cable attached to this port; the cable must meet ISO/DIS 11801 Class D requirements and IEEE 802.3af requirements.

## Straight-through twisted-pair cable for 10 Mbps or 100 Mbps network connections

Because of the Auto-MDIX operation of the 10/100 ports on the switch, for all network connections, to PCs, servers or other end nodes, or to hubs or other switches, you can use straight-through cables.

If any of these ports are given a fixed configuration, for example 100 Mbps/Full Duplex, the ports operate as MDI-X ports, and straight-through cables must be then used for connections to PC NICs and other MDI ports.

### Cable diagram

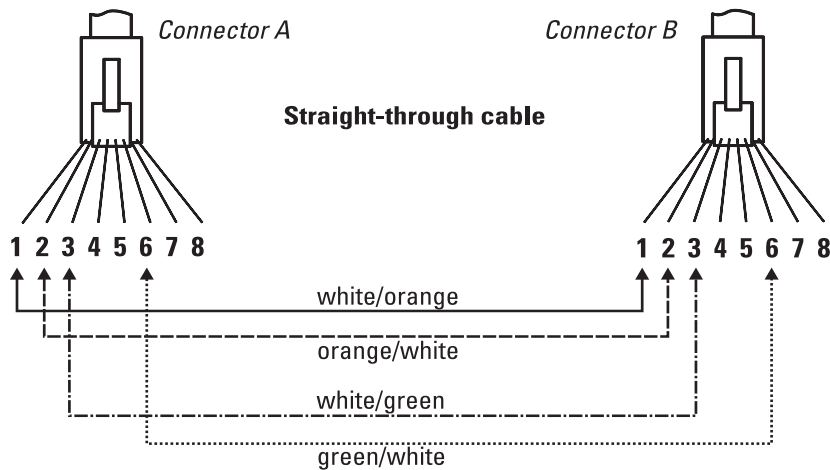

---

### NOTE:

Pins 1 and 2 on connector “A” *must* be wired as a twisted pair to pins 1 and 2 on connector “B”. Pins 3 and 6 on connector “A” *must* be wired as a twisted pair to pins 3 and 6 on connector “B”. Pins 4, 5, 7, and 8 are not used in this application, although they may be wired in the cable.

---

## Pin assignments

Switch end (MDI-X)		Computer, transceiver, or other end	
Signal	Pins	Pins	Signal
receive +	1	1	transmit +
receive -	2	2	transmit -
transmit +	3	3	receive +
transmit -	6	6	receive -

## Crossover twisted-pair cable for 10 Mbps or 100 Mbps network connection

The Auto-MDIX operation of the 10/100 ports on the switch also allows you to use crossover cables for all network connections, to PCs, servers or other end nodes, or to hubs or other switches.

If any of these ports are given a fixed configuration, for example 100 Mbps/Full Duplex, the ports operate as MDI-X ports, and crossover cables *must* be then used for connections to hubs or switches or other MDI-X network devices.

## Cable diagram

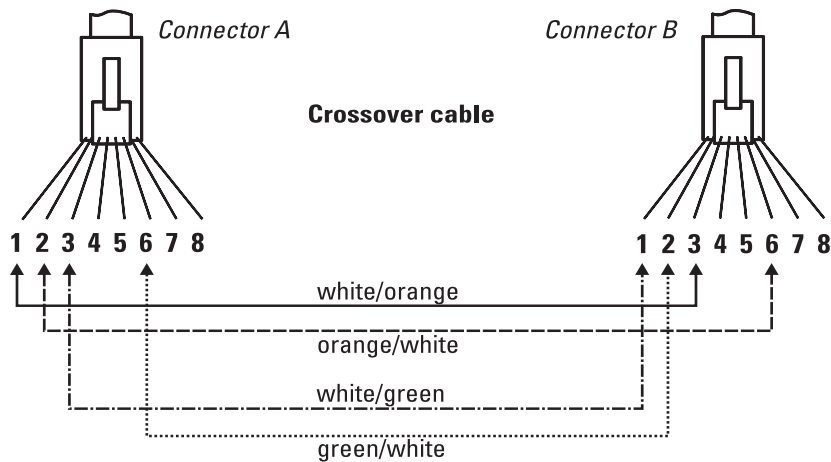

### NOTE:

Pins 1 and 2 on connector "A" *must* be wired as a twisted pair to pins 3 and 6 on connector "B". Pins 3 and 6 on connector "A" *must* be wired as a twisted pair to pins 1 and 2 on connector "B". Pins 4, 5, 7, and 8 are not used in this application, although they may be wired in the cable.

## Pin assignments

Switch end (MDI-X)		Hub or switch port, or other MDI-X port end	
Signal	Pins	Pins	Signal
receive +	1	6	transmit -
receive -	2	3	transmit +
transmit +	3	2	receive -
transmit -	6	1	receive +

## Straight-through twisted-pair cable for 1000 Mbps network connections

1000BASE-T connections require that all four pairs of wires be connected.

## Cable diagram

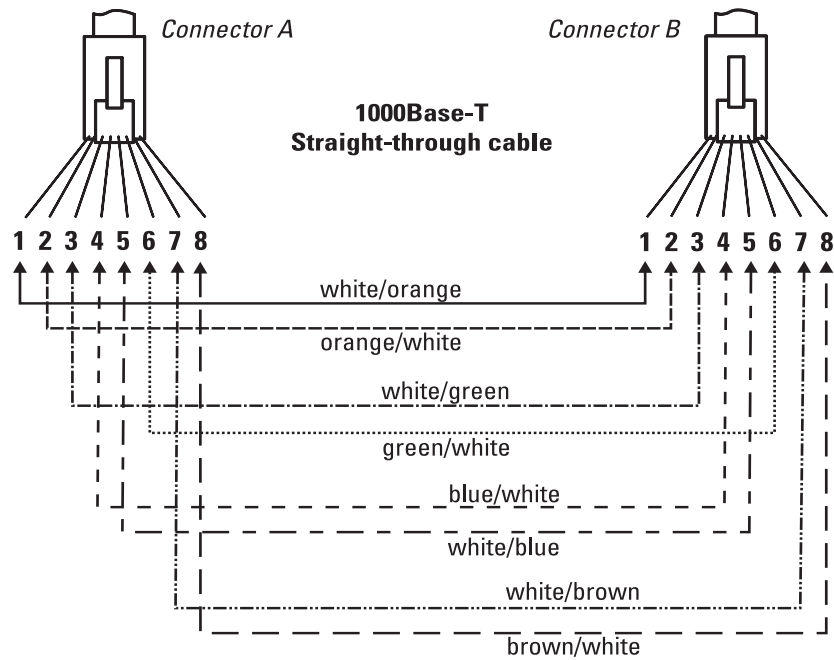

---

### NOTE:

Pins 1 and 2 on connector "A" *must* be wired as a twisted pair to pins 1 and 2 on connector "B".  
Pins 3 and 6 on connector "A" *must* be wired as a twisted pair to pins 3 and 6 on connector "B".  
Pins 4 and 5 on connector "A" *must* be wired as a twisted pair to pins 4 and 5 on connector "B".  
Pins 7 and 8 on connector "A" *must* be wired as a twisted pair to pins 7 and 8 on connector "B".

---

### Pin assignments

For 1000BASE-T operation, all four pairs of wires are used for both transmit and receive.



# 7 Support and other resources

## Accessing Hewlett Packard Enterprise support

- For live assistance, go to the Contact Hewlett Packard Enterprise Worldwide Support website:  
[www.hpe.com/assistance](http://www.hpe.com/assistance)
- To access documentation and support services, go to the Hewlett Packard Enterprise Support Center website:  
[www.hpe.com/support/hpesc](http://www.hpe.com/support/hpesc)

### Information to collect

- Technical support registration number (if applicable)
- Product name, model or version, and serial number
- Operating system name and version
- Firmware version
- Error messages
- Product-specific reports and logs
- Add-on products or components
- Third-party products or components

Hewlett Packard Enterprise offers support 24 hours a day, seven days a week through the use of a number of automated electronic services. Hewlett Packard Enterprise provides up-to-date customer care, support and warranty information at <http://www.hpe.com/networking/support>. Additionally, your Hewlett Packard Enterprise authorized network reseller can provide you with assistance, both with services that they offer and with services offered by Hewlett Packard Enterprise.

## Before calling support

To make most efficient use of the support process, you must retrieve the following information before calling your authorized network reseller or Hewlett Packard Enterprise Support.

Information item	Information location
• Product identification, including SFP/SFP+ transceivers	The front of the switch and on labels on the SFP/SFP+ transceivers
• Details about the switch's status including the software (OS) version, a copy of the switch configuration, a copy of the switch Event Log, and a copy of the switch status and counters information	Switch console: <b>show tech</b> command
• Copy of your network topology map, including network addresses assigned to the relevant devices	Your network records

## Accessing updates

- Some software products provide a mechanism for accessing software updates through the product interface. Review your product documentation to identify the recommended software update method.
- To download product updates, go to either of the following:
  - Hewlett Packard Enterprise Support Center's **Subscription Service/Support Alerts** page:

[www.hpe.com/support/e-updates](http://www.hpe.com/support/e-updates)

- To view and update your entitlements, and to link your contracts, Care Packs, and warranties with your profile, go to the Hewlett Packard Enterprise Support Center **More Information on Access to HP Support Materials** page:

[www.hpe.com/support/AccessToSupportMaterials](http://www.hpe.com/support/AccessToSupportMaterials)

---

**IMPORTANT:** Access to some updates might require product entitlement when accessed through the Hewlett Packard Enterprise Support Center. You must have a Hewlett Packard Enterprise Passport set up with relevant entitlements.

---

- Software updates can be downloaded to the switch through several methods. Switch software updates are available at <http://www.hpe.com/networking/software>.
- For information on methods for downloading and installing software, see the *Basic Operation Guide* for your switch in the HPE Information Library at [www.hpe.com/networking/ResourceCenter](http://www.hpe.com/networking/ResourceCenter).

## Websites

Website	Link
My Networking Support lookup tool	<a href="http://www.hpe.com/networking/support">www.hpe.com/networking/support</a>
Hewlett Packard Enterprise Information Library	<a href="http://www.hpe.com/info/enterprise/docs">www.hpe.com/info/enterprise/docs</a>
Hewlett Packard Enterprise Support Center	<a href="http://www.hpe.com/support/hpesc">www.hpe.com/support/hpesc</a>
Contact Hewlett Packard Enterprise Worldwide	<a href="http://www.hpe.com/assistance">www.hpe.com/assistance</a>
Hewlett Packard Enterprise Support Center's Subscription Service/Support Alerts	<a href="http://www.hpe.com/support/e-updates">www.hpe.com/support/e-updates</a>
Software Download	<a href="http://www.hpe.com/networking/software">www.hpe.com/networking/software</a>
Customer Self Repair	<a href="http://www.hpe.com/support/selfrepair">www.hpe.com/support/selfrepair</a>
Insight Remote Support	<a href="http://www.hpe.com/info/insightremotesupport/docs">www.hpe.com/info/insightremotesupport/docs</a>
Serviceguard Solutions for HP-UX	<a href="http://www.hpe.com/info/hpux-serviceguard-docs">www.hpe.com/info/hpux-serviceguard-docs</a>

## Customer self repair

Hewlett Packard Enterprise customer self repair (CSR) programs allow you to repair your product. If a CSR part needs to be replaced, it will be shipped directly to you so that you can install it at your convenience. Some parts do not qualify for CSR. Your Hewlett Packard Enterprise authorized service provider will determine whether a repair can be accomplished by CSR.

For more information about CSR, contact your local service provider or go to the CSR website:

[www.hpe.com/support/selfrepair](http://www.hpe.com/support/selfrepair)

## Remote support

Remote support is available with supported devices as part of your warranty, Care Pack Service, or contractual support agreement. It provides intelligent event diagnosis, and automatic, secure submission of hardware event notifications to Hewlett Packard Enterprise, which will initiate a fast and accurate resolution based on your product's service level. Hewlett Packard Enterprise strongly recommends that you register your device for remote support.

For more information and device support details, go to the following website:

[www.hpe.com/info/insightremotesupport/docs](http://www.hpe.com/info/insightremotesupport/docs)

## Documentation feedback

Hewlett Packard Enterprise is committed to providing documentation that meets your needs. To help us improve the documentation, send any errors, suggestions, or comments to DocumentationFeedback ([\*\*docsfeedback@hpe.com\*\*](mailto:docsfeedback@hpe.com)). When submitting your feedback, include the document title, part number, edition, and publication date located on the front cover of the document. For online help content, include the product name, product version, help edition, and publication date located on the legal notices page.

## 8 Warranty and regulatory information

For important safety, environmental, and regulatory information, see Safety and Compliance Information for Server, Storage, Power, Networking, and Rack Products, available at [www.hpe.com/support/Safety-Compliance-EnterpriseProducts](http://www.hpe.com/support/Safety-Compliance-EnterpriseProducts).

### Warranty information

**HPE networking products**

[www.hpe.com/support/Networking-Warranties](http://www.hpe.com/support/Networking-Warranties)

### Regulatory information

#### Turkey RoHS material content declaration

Türkiye Cumhuriyeti: EEE Yönetmeliğine Uygundur.

#### Ukraine RoHS material content declaration

Обладнання відповідає вимогам Технічного регламенту щодо обмеження використання деяких небезпечних речовин в електричному та електронному обладнанні, затвердженого постановою Кабінету Міністрів України від 3 грудня 2008 № 1057.

# Index

## Numerics

- 1000Base-BX 44
  - fiber-optic cable specifications 44
- 1000Base-LH 44
  - fiber-optic cable specifications 44
- 1000Base-T
  - 1000Base-T
    - fiber-optic cable specifications 44

## A

- acoustic specifications 41
- auto MDI/MDI-X operation 46, 47
  - HPE Auto-MDIX feature 45

## B

- basic switch configuration
  - IP address 31
  - manager password 31
  - subnet mask 31
  - Switch Setup screen 30
- basic troubleshooting tips 34
- Bootp
  - automatic switch configuration 15, 19, 30
  - for in-band access 24

## C

- cables
  - connecting cables to switch ports 26
  - effects of non-standard cables 34
  - infrastructure requirements 17
  - serial, for direct console connection 24
- cables, twisted pair
  - category 3, 4, 5 46
  - cross-over cable pin-out 47
  - MDI-X to MDI connections 46, 47
  - MDI-X to MDI-X connections 47
  - pin-outs 47, 48
  - straight-through cable pin-out 47, 48
  - switch-to-computer connection 46, 47
  - switch-to-switch or hub connection 47
- cables, twisted-pair
  - HPE Auto-MDIX feature 45
  - wiring rules 46
- cables, twisted-pair connector pin-outs 45
- cabling infrastructure 17
- Clear button
  - restoring factory default configuration 40
  - to delete password protection 32
- CLI prompt, console
  - displaying 25
- configuration
  - checking when troubleshooting 35
  - DHCP/Bootp 15, 19, 30
  - IP address 31
  - IP address, manually 30
  - manager password 31
  - restoring factory defaults 39
  - subnet mask 31

- Switch Setup screen 30
- connecting the switch to a power source 22
- console
  - checking messages during troubleshooting 39
  - displaying the CLI prompt 25
  - features 23
  - how to connect in-band 24
  - how to connect out-of-band 23
  - RJ-45 pinouts 25
  - serial cable connection 24
  - Switch Setup screen 30
  - Telnet access 32
  - terminal configuration 24
- cross-over cable
  - pin-out 47

## D

- desktop switch
  - sample topology 28
- DHCP
  - automatic switch configuration 15, 19, 30
  - for in-band access 24
- diagnostic tests 38
  - checking the console messages 39
  - checking the LEDs 39
  - end-to-end connectivity 39
  - testing the switch only 38
  - testing twisted-pair cabling 39
- downloading new switch software 40

## E

- electrical specifications, switch 41
- environmental specifications, switch 15, 41

## F

- factory default configuration, restoring 39
- features
  - console 23
- fiber-optic cables
  - 1000Base-BX 44
  - 1000Base-LH 44
  - 1000Base-T 44
- flashing LEDs
  - error indications 35
- full-duplex fixed configuration
  - effects on network connections 34

## H

- HPE Auto-MDIX
  - feature description 45

## I

- in-band 30
- in-band console access
  - types of 24
- installation
  - connecting the switch to a power source 22
  - location considerations 17
  - network cable requirements 17

- precautions 17
- site preparation 17
- IP address
  - configuring 31
- IP telephones 28
- L
- LEDs
  - checking during troubleshooting 39
  - error indications 35
- link test 39
- location for the switch, considerations 17
- M
- MDI-X to MDI network cable 46, 47
- MDI-X to MDI-X network cable 47
- mounting the switch
  - in a rack or cabinet
  - precautions 17
- N
- network cables
  - HPE Auto-MDIX feature 45
  - required types 17
  - twisted-pair connector pin-outs 45
  - twisted-pair, wiring rules 46
- network devices
  - connecting to the switch 26
- network ports
  - connecting to 26
- non-standard network cables, effects 34
- O
- out-of-band console access 32
- P
- password
  - configuring 31
- passwords
  - deleting with the Clear button 32
  - if you lose the password 32
- physical specifications, switch 41
- Ping test 39
- pin-outs
  - twisted-pair cables 45
- PoE LED patterns 37
- PoE troubleshooting 37
- port configuration
  - checking when troubleshooting 35
- ports
  - connecting to 26
  - console 23
  - HPE Auto-MDIX feature 45
  - network connections 26
- power source
  - connecting the switch to 22
- precautions
  - mounting the switch 17
  - power requirements 17
- preparing the installation site 17
- Proactive Network tools

- diagnostics with 38
- R
- rack
  - mounting precautions 17
- Reset button
  - restoring factory default configuration 40
- resetting the switch
  - factory default reset 39
  - troubleshooting procedure 38
- RJ-45 console pinouts 25
- S
- safety specifications 42
- Self Test LED
  - behavior during factory default reset 40
- serial cable
  - for direct console connection 24
- specifications
  - acoustic 41
  - electrical 41
  - environmental 15, 41
  - physical 41
  - safety 42
- straight-through cable
  - pin-out 47, 48
- subnet mask
  - configuring 31
- switch
  - connecting to a power source 22
  - downloading new software 40
  - electrical specifications 41
  - environmental specifications 15, 41
  - physical specifications 41
- switch operation
  - verifying after installation 18
- Switch Setup screen 30
  - configuring a subnet mask 31
  - configuring an IP address 31
  - field descriptions 31
- T
- Telnet access to the console 32
- terminal configuration 24
- testing
  - checking the console messages 39
  - checking the LEDs 39
  - diagnostic tests 38
  - end-to-end communications 39
  - link test 39
  - Ping test 39
  - switch operation 38
  - switch-to-device communications 39
  - twisted-pair cabling 39
- tips for troubleshooting 34
- topologies
  - effects of improper topology 35
  - samples of 28
- troubleshooting
  - basic tips 34
  - checking port configuration 35

- checking the console messages 39
- checking the LEDs 39
- common network problems 34
- connecting to fixed full-duplex devices 34
- diagnostic tests 38
- effects of improper topology 35
- effects of non-standard cables 34
- link test 39
- Ping test 39
- Proactive Network tools 38
- restoring factory default configuration 39
- testing connections to other devices 39
- testing end-to-end communications 39
- testing the switch 38
- testing the twisted-pair cables 39
- twisted-pair cable
  - cross-over cable pin-out 47
  - pin-outs 45, 47, 48
  - straight-through cable pin-out 47, 48
  - switch-to-computer connection 46, 47
  - switch-to-switch or hub connection 47
  - testing 39
- twisted-pair ports
  - HPE Auto-MDIX feature 45

V

- VT-100 terminal
  - serial cable connection for 24

W

- wiring rules for twisted-pair cables 46