



**Hewlett Packard**  
Enterprise

# HPE FlexFabric 5940 Switch Series

## Installation Guide

Part number: 5200-2842a  
Document version: 6W104-20170217

© Copyright 2017 Hewlett Packard Enterprise Development LP

The information contained herein is subject to change without notice. The only warranties for Hewlett Packard Enterprise products and services are set forth in the express warranty statements accompanying such products and services. Nothing herein should be construed as constituting an additional warranty. Hewlett Packard Enterprise shall not be liable for technical or editorial errors or omissions contained herein.

Confidential computer software. Valid license from Hewlett Packard Enterprise required for possession, use, or copying. Consistent with FAR 12.211 and 12.212, Commercial Computer Software, Computer Software Documentation, and Technical Data for Commercial Items are licensed to the U.S. Government under vendor's standard commercial license.

Links to third-party websites take you outside the Hewlett Packard Enterprise website. Hewlett Packard Enterprise has no control over and is not responsible for information outside the Hewlett Packard Enterprise website.

### **Acknowledgments**

Intel®, Itanium®, Pentium®, Intel Inside®, and the Intel Inside logo are trademarks of Intel Corporation in the United States and other countries.

Microsoft® and Windows® are either registered trademarks or trademarks of Microsoft Corporation in the United States and/or other countries.

Adobe® and Acrobat® are trademarks of Adobe Systems Incorporated.

Java and Oracle are registered trademarks of Oracle and/or its affiliates.

UNIX® is a registered trademark of The Open Group.

# Contents

<b>Preparing for installation</b> .....	<b>1</b>
Safety recommendations .....	2
Examining the installation site .....	2
Temperature/humidity .....	2
Cleanliness .....	3
EMI .....	3
Laser safety .....	4
Installation tools .....	4
Installation accessories .....	4
<b>Installing the switch</b> .....	<b>7</b>
Installing the switch in a 19-inch rack .....	8
Installation accessories .....	8
Rack-mounting procedures at a glance .....	10
Attaching the mounting brackets, chassis rails, and grounding cable to the chassis .....	11
Attaching the slide rails to the rack .....	16
Mounting the switch in the rack .....	17
Grounding the switch .....	21
Grounding the switch with a grounding strip .....	21
Grounding the switch by using the AC power cord .....	22
Installing/removing a fan tray .....	23
Installing a fan tray .....	23
Removing a fan tray .....	25
Installing/removing a power supply .....	25
Installing a power supply .....	26
Removing a power supply .....	27
Connecting the power cord .....	28
Connecting an AC power cord .....	29
Connecting a DC power cord .....	29
Installing/removing an interface module .....	30
Installing an interface module .....	30
Removing an interface module .....	31
Verifying the installation .....	32
<b>Accessing the switch for the first time</b> .....	<b>33</b>
Setting up the configuration environment .....	33
Connecting the console cable .....	33
Serial console cable .....	33
USB mini console cable .....	34
Connection procedure .....	34
Setting terminal parameters .....	36
Powering on the switch .....	36
<b>Setting up an IRF fabric</b> .....	<b>38</b>
IRF fabric setup flowchart .....	38
Planning IRF fabric setup .....	39
Planning IRF fabric size and the installation site .....	39
Identifying the master switch and planning IRF member IDs .....	39
Planning IRF topology and connections .....	40
Identifying physical IRF ports on the member switches .....	41
Planning the cabling scheme .....	41
Configuring basic IRF settings .....	43
Connecting the physical IRF ports .....	43
Accessing the IRF fabric to verify the configuration .....	43
<b>Maintenance and troubleshooting</b> .....	<b>44</b>
Power supply failure .....	44

Fan tray failure .....	44
Configuration terminal problems .....	45
No display on the configuration terminal .....	45
Garbled display on the configuration terminal .....	45
<b>Appendix A Chassis views and technical specifications .....</b>	<b>46</b>
Chassis views .....	46
HPE 5940 32QSFP+.....	46
HPE 5940 48SFP+ 6QSFP+ .....	47
HPE 5940 48XGT 6QSFP+.....	48
HPE 5940 48SFP+ 6QSFP28.....	49
HPE 5940 48XGT 6QSFP28 .....	50
HPE FlexFabric 5940 2-slot.....	51
HPE FlexFabric 5940 4-slot.....	52
Technical specifications .....	54
<b>Appendix B FRUs and compatibility matrixes .....</b>	<b>58</b>
Power supplies.....	59
Fan trays.....	60
Interface modules .....	61
<b>Appendix C Ports and LEDs .....</b>	<b>63</b>
Ports.....	63
Console port.....	63
Management Ethernet port.....	63
USB port.....	64
SFP+ port .....	65
QSFP+ port.....	67
QSFP28 port .....	69
1/10GBASE-T autosensing Ethernet port.....	70
LEDs .....	71
System status LED .....	71
SFP+ port LED .....	71
QSFP+ port LED .....	71
QSFP28 port LED .....	72
Management Ethernet port LEDs .....	72
1/10GBASE-T autosensing Ethernet port LEDs.....	73
Fan tray alarm LEDs .....	73
<b>Appendix D Cooling system.....</b>	<b>74</b>
<b>Document conventions and icons .....</b>	<b>76</b>
Conventions.....	76
Network topology icons .....	77
<b>Support and other resources.....</b>	<b>78</b>
Accessing Hewlett Packard Enterprise Support.....	78
Accessing updates .....	78
Websites .....	79
Customer self repair .....	79
Remote support .....	79
Documentation feedback .....	79
<b>Index .....</b>	<b>81</b>

# Preparing for installation

Table 1 describes HPE FlexFabric 5940 Switch Series models, power supplies, and fan trays.

**Table 1 HPE FlexFabric 5940 Switch Series models, power supplies, and fan trays**

Product code	HPE description	Alias
<b>HPE FlexFabric 5940 switches</b>		
JH390A	HPE FlexFabric 5940 48SFP+ 6QSFP28 Switch	HPE 5940 48SFP+ 6QSFP28
JH391A	HPE FlexFabric 5940 48XGT 6QSFP28 Switch	HPE 5940 48XGT 6QSFP28
JH394A	HPE FlexFabric 5940 48XGT 6QSFP+ Switch	HPE 5940 48XGT 6QSFP+
JH395A	HPE FlexFabric 5940 48SFP+ 6QSFP+ Switch	HPE 5940 48SFP+ 6QSFP+
JH396A	HPE FlexFabric 5940 32QSFP+ Switch	HPE 5940 32QSFP+
JH397A	HPE FlexFabric 5940 2-slot Switch	HPE 5940 2-slot
JH398A	HPE FlexFabric 5940 4-slot Switch	HPE 5940 4-slot
<b>Power supplies</b>		
JC680A	HPE 58x0AF 650W AC Power Supply	650W AC
JH336A	HPE FlexFabric Switch 650W 48V Hot Plug NEBS-compliant DC Power Supply	650W DC
JG900A	HPE A58x0AF 300W AC Power Supply	300W AC
JG901A	HPE A58x0AF 300W DC Power Supply	300W DC
<b>Fan trays</b>		
JC682A	HPE 58x0AF Back (Power Side) to Front (Port Side) Airflow Fan Tray	LSWM1FANSC
JC683A	HPE 58x0AF Front (Port Side) to Back (Power Side) Airflow Fan Tray	LSWM1FANSCB
JG552A	HPE X711 Front (Port Side) to Back (Power Side) Airflow High Volume Fan Tray	LSWM1HFANSCB
JG553A	HPE X712 Back (Power Side) to Front (Port Side) Airflow High Volume Fan Tray	LSWM1HFANSC
JH185A	HPE 5930 4-slot Back (Power Side) to Front (Port Side) Airflow Fan Tray	LSWM1BFANSC
JH186A	HPE 5930 4-slot Front (Port Side) to Back (Power Side) Airflow Fan Tray	LSWM1BFANSCB

For regulatory identification purposes, the HPE FlexFabric 5940 Switches are assigned Regulatory Model Numbers (RMNs). The RMNs for these products are listed below.

Product code	RMN	Description
JH390A	BJNGA-AD0068	HPE FlexFabric 5940 48SFP+ 6QSFP28 Switch
JH391A	BJNGA-AD0069	HPE FlexFabric 5940 48XGT 6QSFP28 Switch
JH394A	BJNGA-AD0061	HPE FlexFabric 5940 48XGT 6QSFP+ Switch
JH395A	BJNGA-AD0060	HPE FlexFabric 5940 48SFP+ 6QSFP+ Switch

Product code	RMN	Description
JH396A	BJNGA-AD0022	HPE FlexFabric 5940 32QSFP+ Switch
JH397A	BJNGA-AD0049	HPE FlexFabric 5940 2-slot Switch
JH398A	BJNGA-AD0050	HPE FlexFabric 5940 4-slot Switch

## Safety recommendations

To avoid any equipment damage or bodily injury caused by incorrect use, read the following safety recommendations before installation. Note that the recommendations do not cover every possible hazardous condition.

- Before cleaning the switch, remove all power cords from the switch. Do not clean the switch with wet cloth or liquid.
- Do not place the switch near water or in a damp environment. Prevent water or moisture from entering the switch chassis.
- Do not place the switch on an unstable case or desk. The switch might be severely damaged in case of a fall.
- Ensure good ventilation of the equipment room and keep the air inlet and outlet vents of the switch free of obstruction.
- Connect the yellow-green protection grounding cable before power-on.
- Make sure the operating voltage is in the required range.
- To avoid electrical shocks, do not open the chassis while the switch is operating or when the switch is just powered off.
- When replacing FRUs, including power supplies, interface modules, and fan trays, wear an ESD wrist strap to avoid damaging the units.

## Examining the installation site

The HPE FlexFabric 5940 switches must be used indoors.

Mount your switch in a rack and verify the following items:

- Adequate clearance is reserved at the air inlet and outlet vents for ventilation.
- The rack has a good ventilation system.
- Identify the hot aisle and cold aisle at the installation site, and make sure ambient air flows into the switch from the cold aisle and exhausts to the hot aisle.
- Identify the airflow designs of neighboring devices, and prevent hot air flowing out of the bottom device from entering the top device.
- The rack is sturdy enough to support the switch and its accessories.
- The rack is reliably grounded.

To ensure correct operation and long service life of your switch, install it in an environment that meets the requirements described in the following subsections.

## Temperature/humidity

Maintain appropriate temperature and humidity in the equipment room.

- Lasting high relative humidity can cause poor insulation, electricity leakage, mechanical property change of materials, and metal corrosion.

- Lasting low relative humidity can cause washer contraction and ESD and cause problems including loose screws and circuit failure.
- High temperature can accelerate the aging of insulation materials and significantly lower the reliability and lifespan of the switch.

For the temperature and humidity requirements of different switch models, see "[Appendix A Chassis views and technical specifications](#)."

## Cleanliness

Dust buildup on the chassis might result in electrostatic adsorption, which causes poor contact of metal components and contact points, especially when indoor relative humidity is low. In the worst case, electrostatic adsorption can cause communication failure.

**Table 2 Dust concentration limit in the equipment room**

Substance	Concentration limit (particles/m <sup>3</sup> )
Dust	≤ 3 x 10 <sup>4</sup> (no visible dust on the tabletop over three days)
<b>NOTE:</b> Dust diameter ≥ 5 μm	

The equipment room must also meet strict limits on salts, acids, and sulfides to eliminate corrosion and premature aging of components, as shown in [Table 3](#).

**Table 3 Harmful gas limits in the equipment room**

Gas	Maximum concentration (mg/m <sup>3</sup> )
SO <sub>2</sub>	0.2
H <sub>2</sub> S	0.006
NH <sub>3</sub>	0.05
Cl <sub>2</sub>	0.01

## EMI

All electromagnetic interference (EMI) sources, from outside or inside of the switch and application system, adversely affect the switch in the following ways:

- A conduction pattern of capacitance coupling.
- Inductance coupling.
- Electromagnetic wave radiation.
- Common impedance (including the grounding system) coupling.

To prevent EMI, use the following guidelines:

- If AC power is used, use a single-phase three-wire power receptacle with protection earth (PE) to filter interference from the power grid.
- Keep the switch far away from radio transmitting stations, radar stations, and high-frequency devices.
- Use electromagnetic shielding, for example, shielded interface cables, when necessary.
- To prevent signal ports from getting damaged by overvoltage or overcurrent caused by lightning strikes, route interface cables only indoors.

# Laser safety

**⚠ WARNING!**

Do not stare into any fiber port when the switch has power. The laser light emitted from the optical fiber might hurt your eyes.

The HPE FlexFabric 5940 switches are Class 1 laser devices.


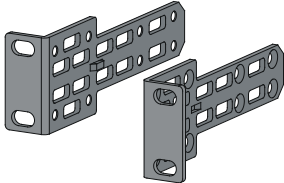
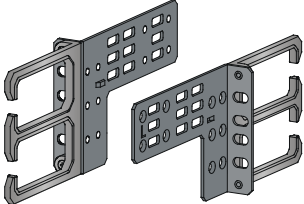
# Installation tools

No installation tools are provided with the switch. Prepare the following tools yourself:

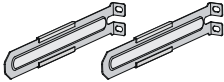
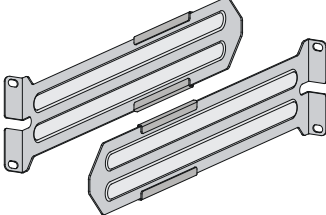
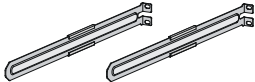


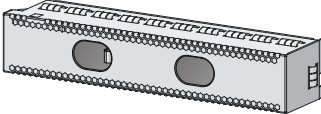
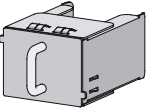

- Phillips screwdriver.
- ESD wrist strap.
- Marker.


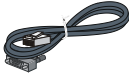

# Installation accessories

**Table 4 Installation accessories**

Product code	Description	Quantity	Applicable models
5066-0850	1 U mounting bracket kit (including one pair of mounting brackets and eight M4 countersunk screws) 	1 kit	All HPE FlexFabric 5940 switches
5190-0719	Mounting brackets for the HPE 5940 2-slot switch 	1 kit	HPE 5940 2-slot
5190-0720	Mounting brackets for the HPE 5940 4-slot switch 	1 kit	HPE 5940 4-slot



Product code	Description	Quantity	Applicable models
5185-8681	<p>1U short slide rail kit (including one pair of slide rails and four M4 countersunk screws)</p> 	1 kit	<ul style="list-style-type: none"> <li>HPE 5940 32QSFP+</li> <li>HPE 5940 48XGT 6QSFP28</li> <li>HPE 5940 48XGT 6QSFP+</li> </ul>
5185-8684	<p>2U short slide rail kit (including one pair of slide rails and four M4 countersunk screws)</p> 	1 kit	<ul style="list-style-type: none"> <li>HPE 5940 4-slot</li> </ul>
5185-8713	<p>1 U long slide rail kit (including one pair of slide rails and four M4 countersunk screws)</p> 	1 kit	<ul style="list-style-type: none"> <li>HPE 5940 48SFP+ 6QSFP28</li> <li>HPE 5940 48SFP+ 6QSFP+</li> </ul>
5184-6723	<p>Grounding cable</p> 	1	All HPE FlexFabric 5940 switches
5185-9579	<p>Grounding screw</p> 	2	All HPE FlexFabric 5940 switches
5003-2403	<p>Interface module filler module</p> 	1	<ul style="list-style-type: none"> <li>HPE 5940 2-slot</li> <li>HPE 5940 4-slot</li> </ul>
5185-8676	<p>Power supply filler panel</p> 	1	All HPE FlexFabric 5940 switches
5185-8688 5400-0249	<p>DC power cord</p>  <p>The power cord color code scheme is for illustration only. The cable delivered for your country or region might use a different color scheme.</p>	1	650W DC power supply

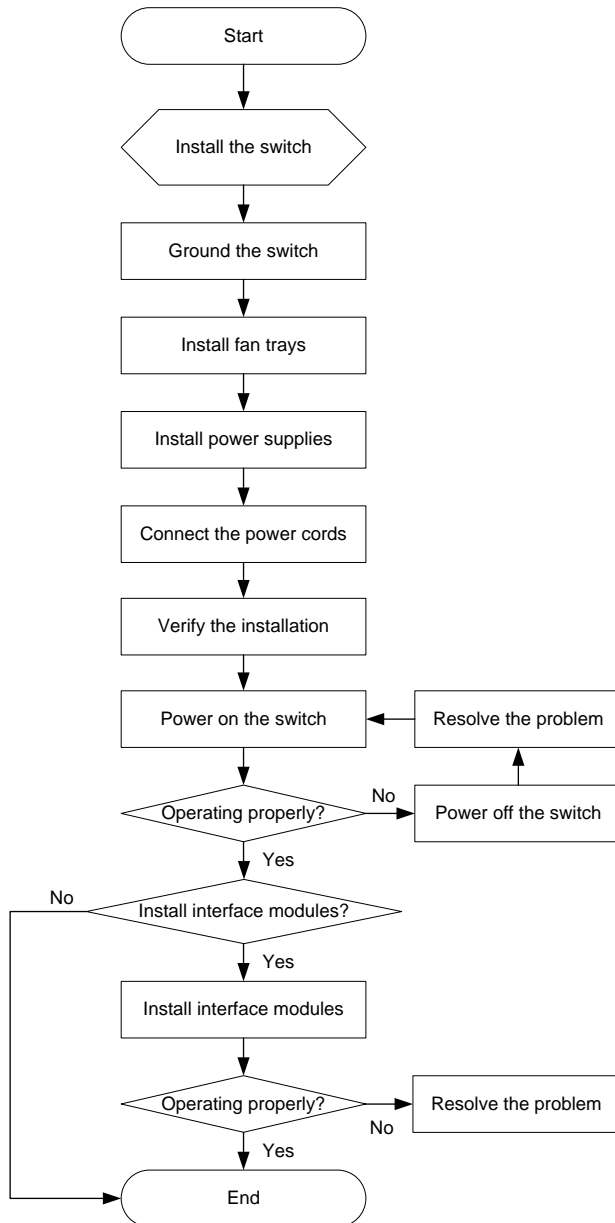
Product code	Description	Quantity	Applicable models
5185-8748	Removable cable tie 	1	All power supplies
5185-8627	Console cable 	1	All HPE FlexFabric 5940 switches
5187-9022	QSFP+ dust plug 	As required	HPE 5940 32QSFP+

# Installing the switch

**△ CAUTION:**

Keep the tamper-proof seal on a mounting screw on the chassis cover intact, and if you want to open the chassis, contact Hewlett Packard Enterprise for permission. Otherwise, Hewlett Packard Enterprise shall not be liable for any consequence caused thereby.

**Figure 1 Hardware installation flow**



# Installing the switch in a 19-inch rack

**ⓘ IMPORTANT:**

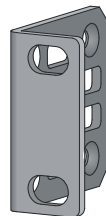
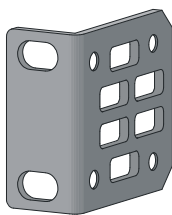
To install an HPE FlexFabric 5940 switch (except HPE 5940 48SFP+ 6QSFP+ and HPE 5940 48SFP+ 6QSFP28 switches) in a 19-inch rack, make sure the rack depth is a minimum of 1000 mm (39.37 in) so that the rack door can be closed easily.

## Installation accessories

**Table 5 Installation accessories**

Switch model	Mounting brackets (provided)	Cable management brackets	Rack mounting rail kit (provided)
<ul style="list-style-type: none"> <li>HPE 5940 32QSFP+</li> <li>HPE 5940 48XGT 6QSFP+</li> <li>HPE 5940 48XGT 6QSFP28</li> </ul>	1U high, one pair. See <a href="#">Figure 2</a> .	N/A	1U high, including one pair of chassis rails and one pair of slide rails. See <a href="#">Figure 5</a> .
<ul style="list-style-type: none"> <li>HPE 5940 48SFP+ 6QSFP+</li> <li>HPE 5940 48SFP+ 6QSFP28</li> </ul>	1U high, one pair. See <a href="#">Figure 2</a> .	N/A	1U high, including one pair of chassis rails and one pair of long slide rails. See <a href="#">Figure 7</a> .
HPE 5940 2-slot	1U high, one pair. See <a href="#">Figure 3</a> .	N/A	1U high, including one pair of chassis rails and one pair of slide rails. See <a href="#">Figure 5</a> .
HPE 5940 4-slot	2U high, one pair. See <a href="#">Figure 4</a> .	One pair (provided). See <a href="#">Figure 4</a> .	2U high, including one pair of chassis rails and one pair of slide rails. See <a href="#">Figure 6</a> .

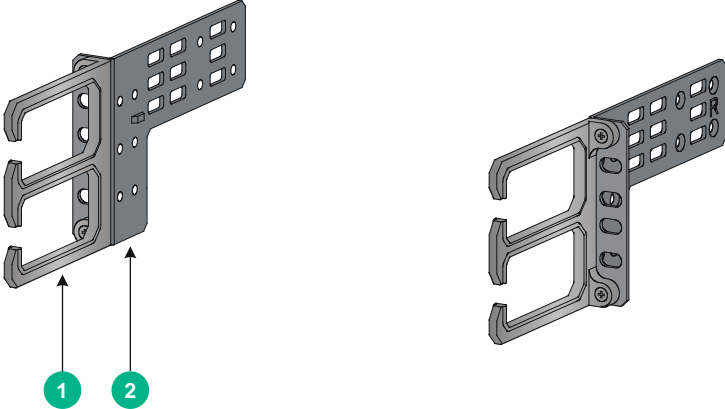
**Figure 2 Mounting brackets**



**Figure 3 Mounting brackets for the HPE 5940 2-slot switch**

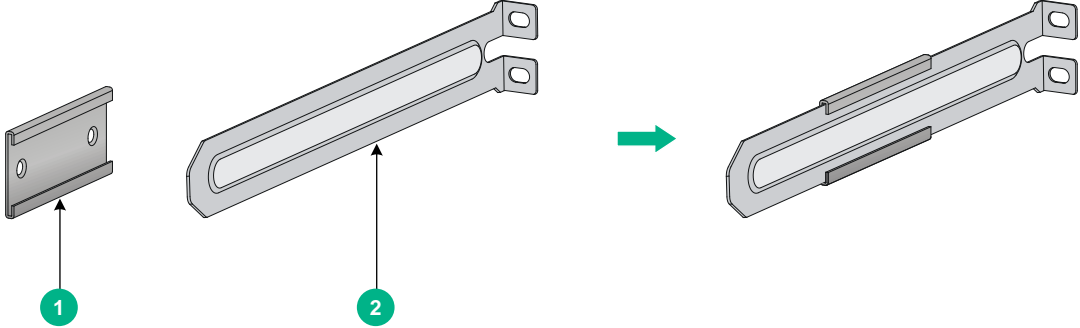


**Figure 4 Mounting brackets for the HPE 5940 4-slot Switch**



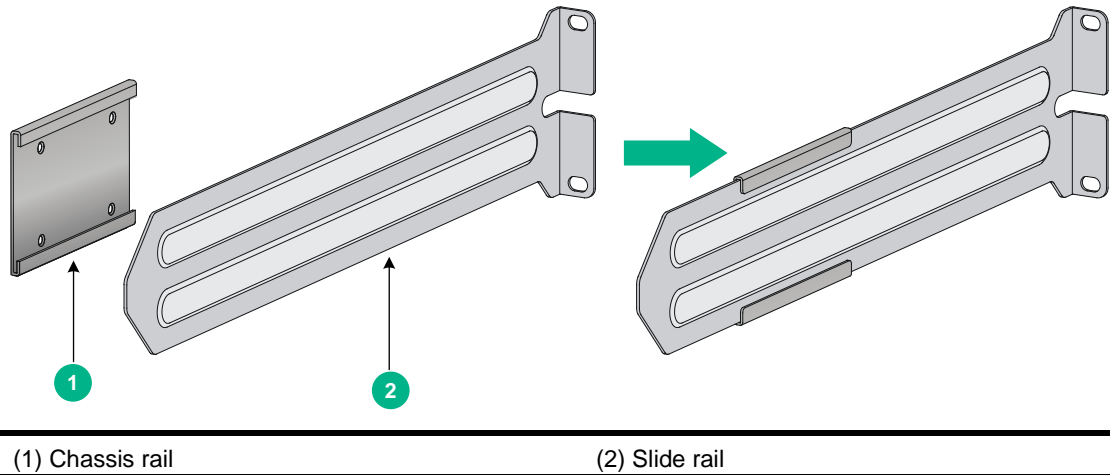
- 
- (1) Cable management bracket
  - (2) Mounting bracket
- 

**Figure 5 1U chassis rail and short slide rail**

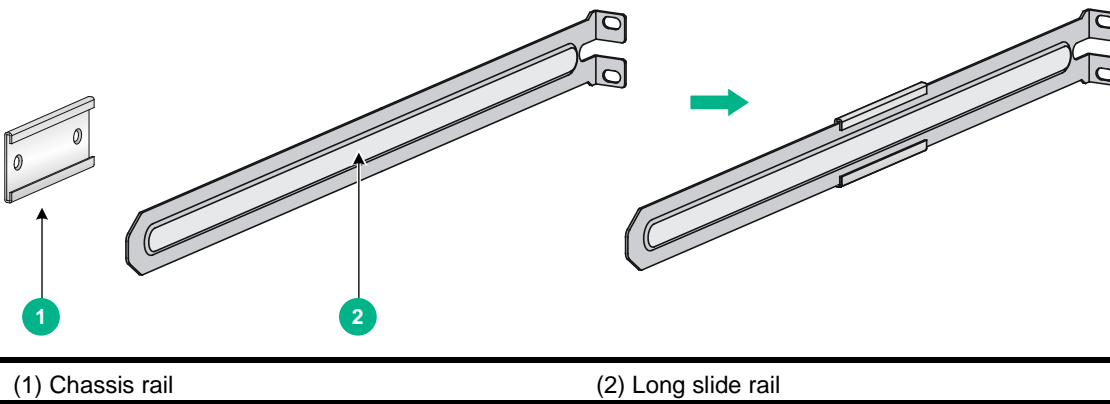


- 
- (1) Chassis rail
  - (2) Slide rail
-

**Figure 6 2U chassis rail and short slide rail**

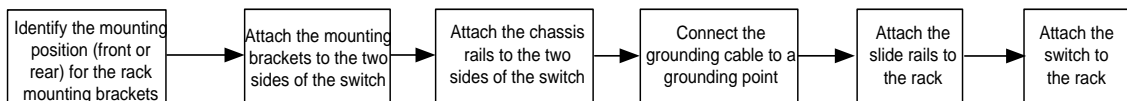


**Figure 7 1U chassis rail and long slide rail**



## Rack-mounting procedures at a glance

**Figure 8 Rack-mounting procedure**



**NOTE:**

If a rack shelf is available, you can put the switch on the rack shelf, slide the switch to an appropriate location, and attach the switch to the rack with the mounting brackets.

- Follow these guidelines when you install the switch in a 19-inch rack:
- The distance between the front and rear posts of the rack must meet the requirements described in [Table 6](#).
- To secure the switch to the rack, you must install not only mounting brackets, but also chassis rails and slide rails.

**Table 6 Distance requirements between the front and rear rack posts**

Switch model	Installation method	Minimum distance between the front and rear rack posts	Maximum distance between the front and rear rack posts
HPE 5940 32QSFP+	Using mounting brackets and short slide rails (provided)	405 mm (15.94 in)	834 mm (32.83 in)
HPE 5940 48SFP+ 6QSFP+	Using mounting brackets and long slide rails (provided)	621 mm (24.45 in)	854 mm (33.62 in)
	Using mounting brackets and short slide rails (optional)	401 mm (15.79 in)	634 mm (24.96 in)
HPE 5940 48XGT 6QSFP+	Using mounting brackets and short slide rails (provided)	405 mm (15.94 in)	834 mm (32.83 in)
HPE 5940 48SFP+ 6QSFP28	Using mounting brackets and long slide rails (provided)	621 mm (24.45 in)	854 mm (33.62 in)
	Using mounting brackets and short slide rails (optional)	401 mm (15.79 in)	634 mm (24.96 in)
HPE 5940 48XGT 6QSFP28	Using mounting brackets and short slide rails (provided)	405 mm (15.94 in)	834 mm (32.83 in)
HPE 5940 2-slot	Using mounting brackets and slide rails (provided)	520 mm (20.47 in)	769 mm (30.28 in)
HPE 5940 4-slot	Using mounting brackets and slide rails (provided)	518 mm (20.39 in)	858 mm (33.78 in)

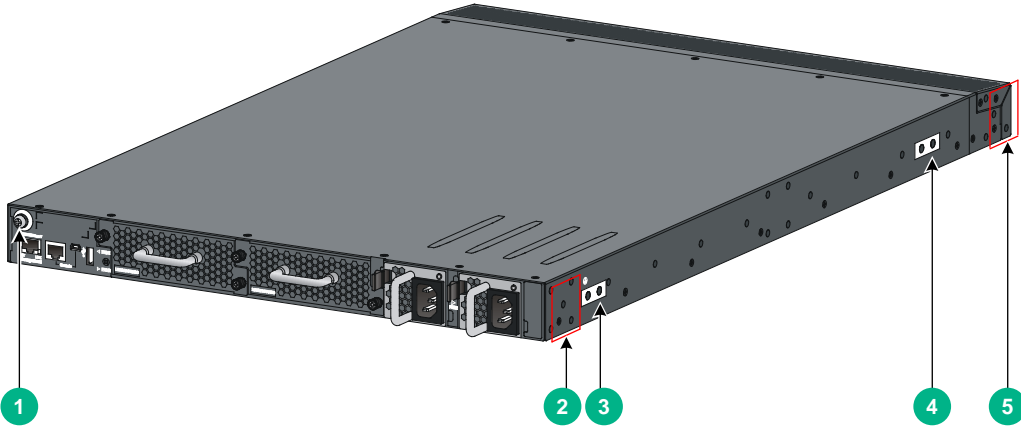
## Attaching the mounting brackets, chassis rails, and grounding cable to the chassis

The switch has one mounting position near the network ports and one mounting position near the power supplies for mounting brackets.

The HPE 5940 48SFP+ 6QSFP28, HPE 5940 48XGT 6QSFP28, HPE 5940 48XGT 6QSFP+, HPE 5940 48SFP+ 6QSFP+, HPE 5940 4-slot, and HPE 5940 32QSFP+ switches provide three grounding points: primary grounding point (with a grounding sign), auxiliary grounding point 1, and auxiliary grounding point 2. The HPE 5940 2-slot switch provides two grounding points: primary grounding point (with a grounding sign) and auxiliary grounding point 1.

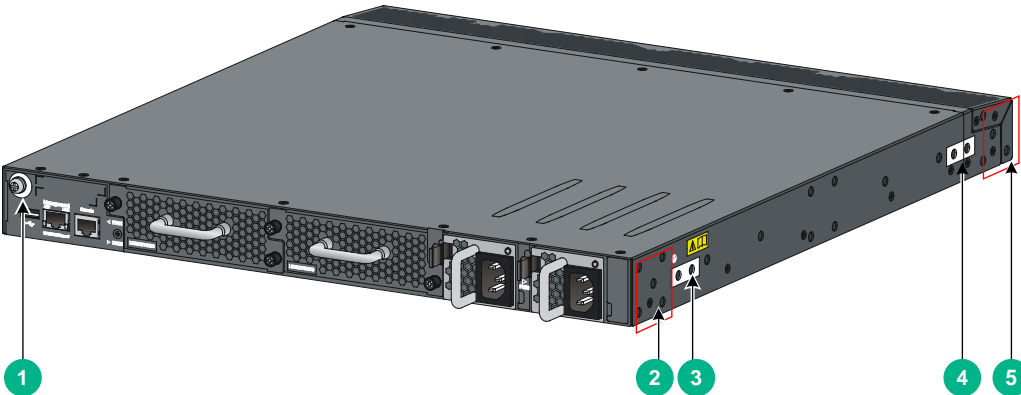
The mounting brackets and chassis rails installation procedures are the same for All HPE FlexFabric 5940 switches.

**Figure 9 Mounting and grounding positions on the HPE 5940 32QSFP+ switch**



- |   |   |
|---|---|
| (1) Auxiliary grounding point 2         | (2) Power supply-side mounting position |
| (3) Primary grounding point             | (4) Auxiliary grounding point 1         |
| (5) Network port-side mounting position |   |

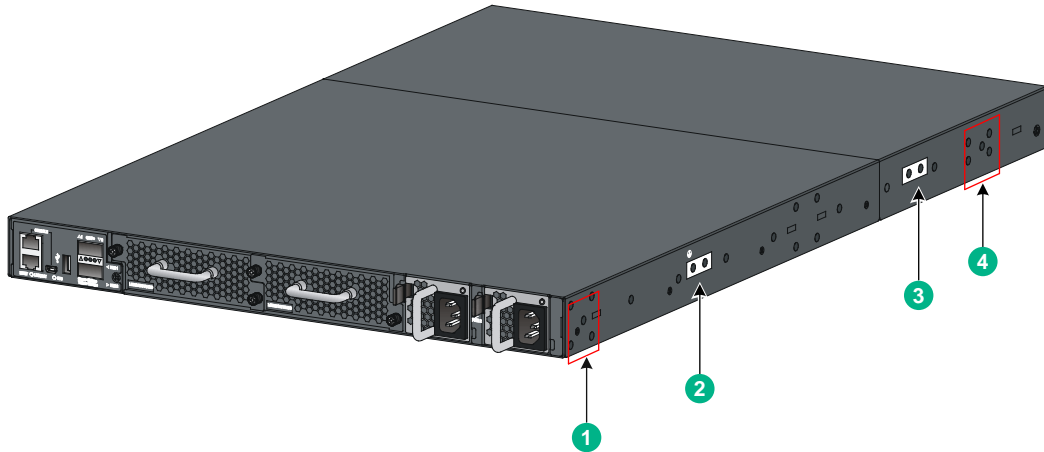
**Figure 10 Mounting and grounding positions on the HPE 5940 48SFP+ 6QSFP+ switch**



- |   |   |
|---|---|
| (1) Auxiliary grounding point 2         | (2) Power supply-side mounting position |
| (3) Primary grounding point             | (4) Auxiliary grounding point 1         |
| (5) Network port-side mounting position |   |



**Figure 11 Mounting and grounding positions on the 5940 2-slot switch**



---

(1) Power supply-side mounting position	(2) Primary grounding point
(3) Auxiliary grounding point 1	(4) Network port-side mounting position

---

### Attaching the mounting brackets and chassis rails to the chassis

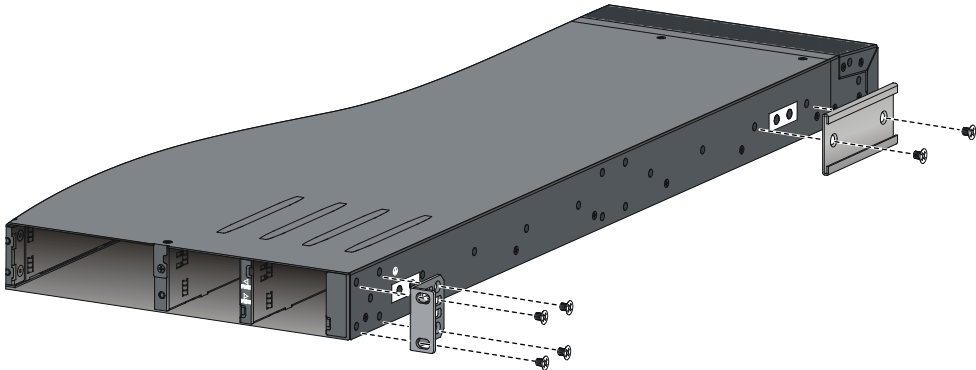
1. Align the mounting brackets with the screw holes in the chassis. Use M4 screws (provided) to attach the mounting brackets to the chassis.
  - o To install the mounting brackets at the power supply-side mounting position, see [Figure 12](#), [Figure 14](#), and [Figure 16](#).
  - o To install the mounting brackets at the network port-side mounting position, see [Figure 13](#), [Figure 15](#), and [Figure 17](#).
2. Align the chassis rails with the rail mounting holes in the chassis:
  - o If the mounting brackets are in the power supply-side mounting position, align the chassis rails with the screw holes at the front of the side panels (see [Figure 12](#), [Figure 14](#), and [Figure 16](#)).
  - o If the mounting brackets are in the network port-side mounting position, align the chassis rails with the screw holes at the rear of the side panels (see [Figure 13](#), [Figure 15](#), and [Figure 17](#)).
3. Use M4 screws (provided) to attach the chassis rails to the chassis.

---

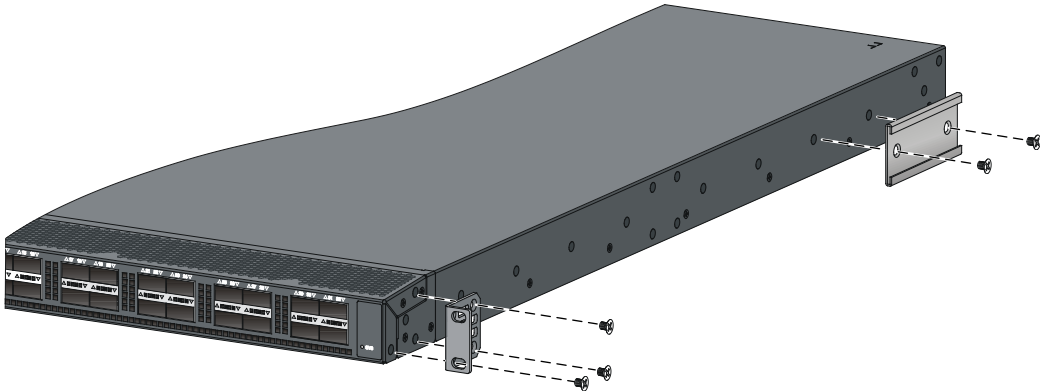
#### NOTE:

- Secure the mounting brackets and chassis rails to both sides of the chassis in the same way.
  - To install the mounting brackets at the network port-side mounting position on the HPE 5940 2-slot and HPE 5940 4-slot switches, use the four screw holes nearest to the network port side. To install the mounting brackets at the power supply-side mounting position on the HPE 5940 2-slot and HPE 5940 4-slot switches, use the four screw holes nearest to the power module side.
-

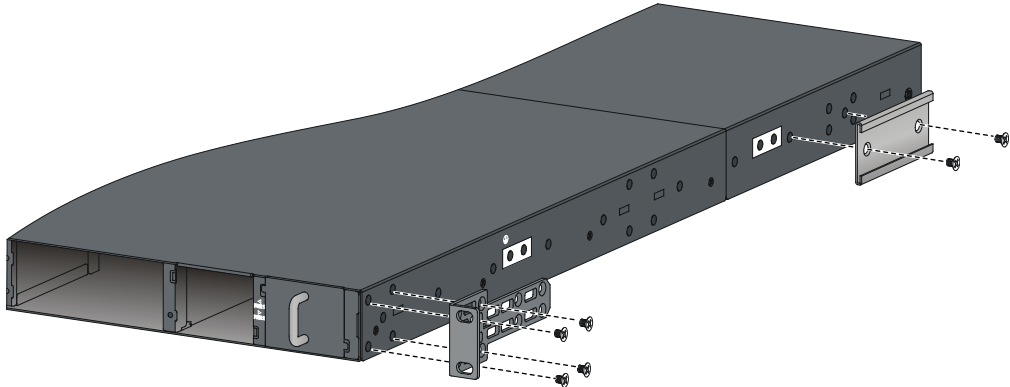
**Figure 12 Attaching the mounting brackets and chassis rails to the HPE 5940 32QSFP+ switch (power supply-side mounting position for the mounting brackets)**



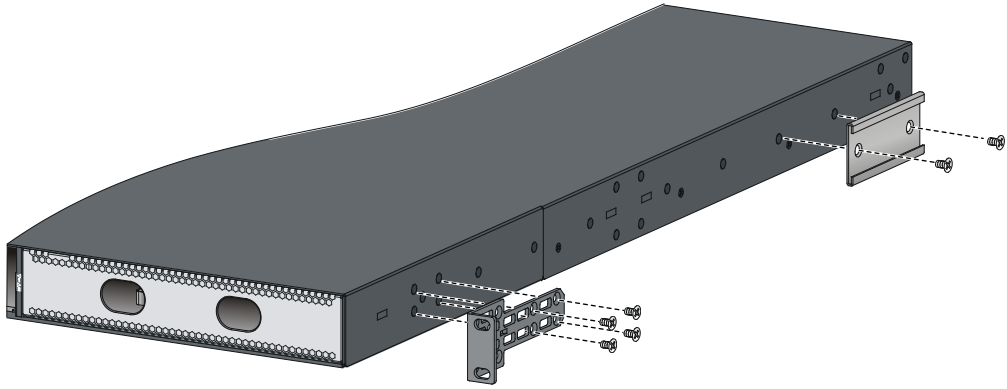
**Figure 13 Attaching the mounting brackets and chassis rails to the HPE 5940 32QSFP+ switch (network port-side mounting position for the mounting brackets)**



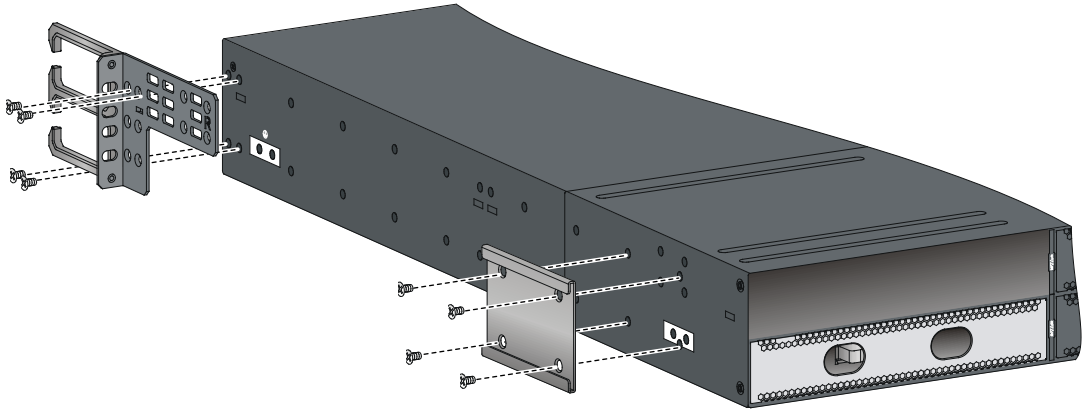
**Figure 14 Attaching the mounting brackets and chassis rails to the HPE 5940 2-slot switch (power supply-side mounting position for the mounting brackets)**



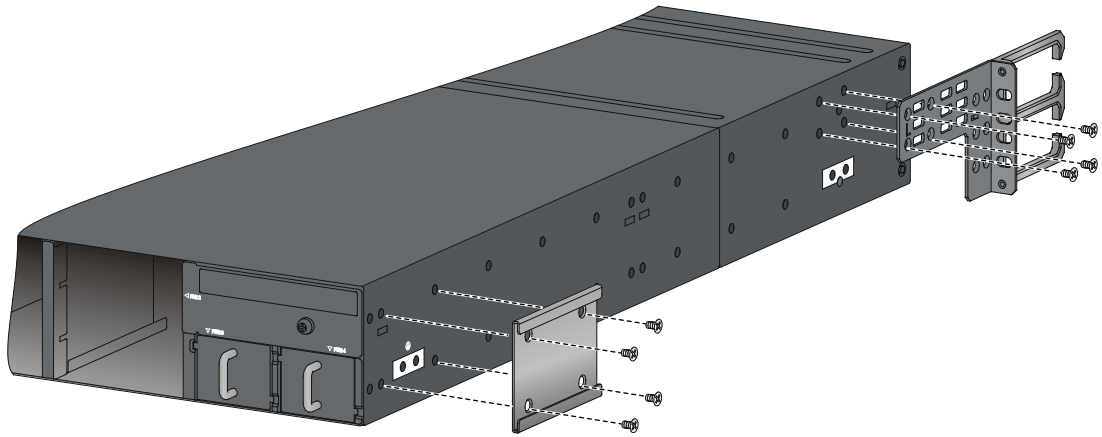
**Figure 15 Attaching the mounting brackets and chassis rails to the HPE 5940 2-slot switch (network port-side mounting position for the mounting brackets)**



**Figure 16 Attaching the mounting brackets and chassis rails to the HPE 5940 4-slot switch (power supply-side mounting position for the mounting brackets)**



**Figure 17 Attaching the mounting brackets and chassis rails to the HPE 5940 4-slot switch (network port-side mounting position for the mounting brackets)**



## Connecting the grounding cable to the chassis

### **⚠ CAUTION:**

Select grounding points as required. The primary grounding point and auxiliary grounding point 1 are located on the left side panel. If you use one of these grounding points, you must connect the grounding cable to the grounding point before you mount the switch in the rack.

As a best practice, use the primary grounding point or auxiliary grounding point 1 because the grounding cable and grounding screw that come with the switch are suitable only for these two grounding points.

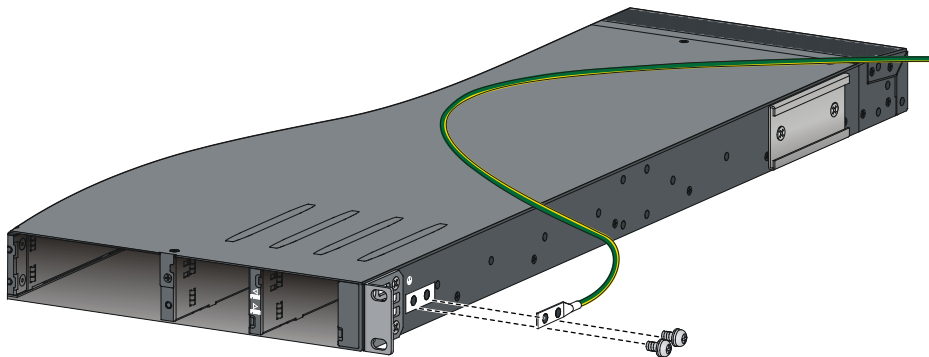
To use auxiliary grounding point 2, prepare a grounding cable yourself.

This section uses the primary grounding point on the HPE 5940 32QSFP+ switch as an example.

To connect the grounding cable to a grounding point:

1. Choose a grounding point.
2. Unpack the grounding cable and grounding screws.  
You can use the cable and screws shipped with the switch only for connecting to the primary grounding point or auxiliary grounding point 1.
3. Align the two-hole grounding lug at one end of the cable with the grounding holes of the grounding point, insert the grounding screws into the holes, and tighten the screws with a screwdriver, as shown in [Figure 18](#).

**Figure 18 Attaching the grounding cable to the primary grounding point on the HPE 5940 32QSFP+ switch**



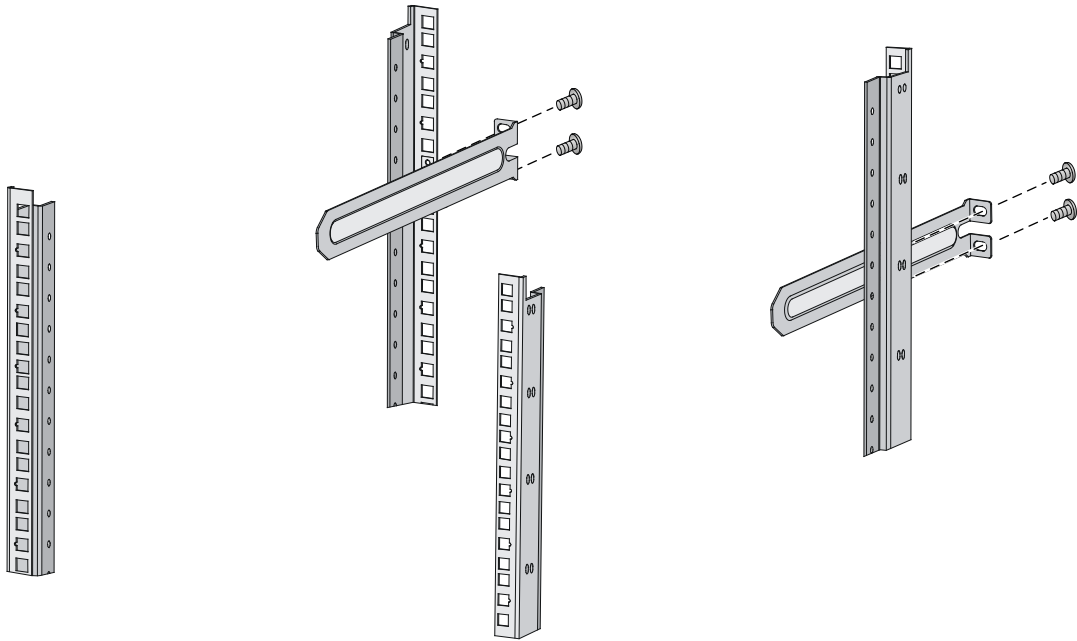
## Attaching the slide rails to the rack

The procedures are the same for attaching 1U and 2U slide rails to the rack. This section uses the 1U slide rails as an example.

To attach the slide rails to the rack:

1. Identify the rack attachment position for the slide rails.
2. Install cage nuts (user-supplied) in the mounting holes in the rack posts.
3. Align the screw holes in one slide rail with the cage nuts in the rack post on one side, and use screws (user-supplied) to attach the slide rail to the rack, as shown in [Figure 19](#).
4. Repeat the preceding steps to attach the other slide rail to the rack post on the other side.  
Keep the two slide rails at the same height so the slide rails can attach into the chassis rails.

**Figure 19 Installing the 1U slide rails**



## Mounting the switch in the rack

This task requires two people.

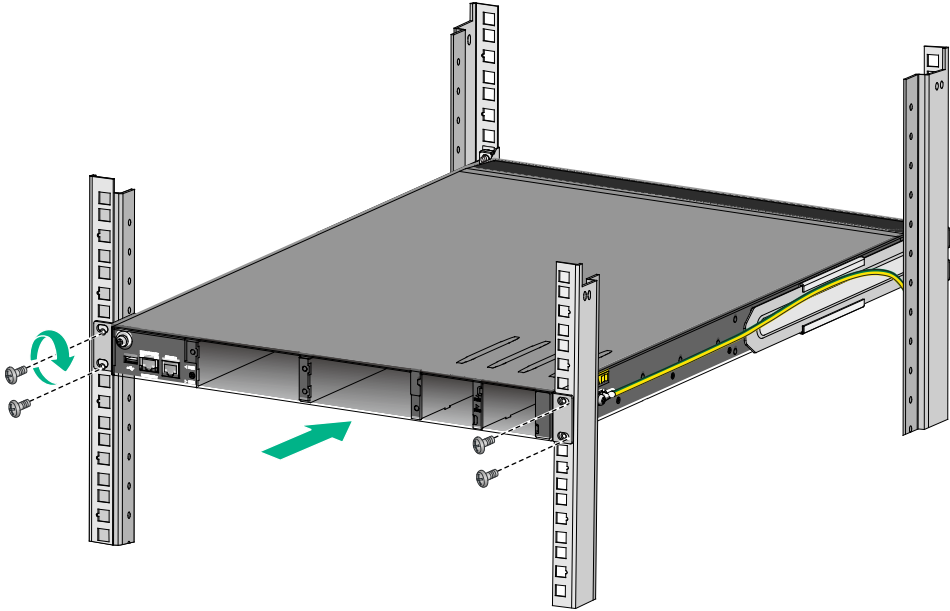
To mount the switch in the rack:

1. Wear an ESD wrist strap and make sure it makes good skin contact and is reliably grounded.
2. Verify that the mounting brackets and chassis rails have been securely attached to the switch chassis.
3. Verify that the slide rails have been correctly attached to the rear rack posts.
4. Install cage nuts (user-supplied) to the front rack posts and make sure they are at the same level as the slide rails.
5. One person performs the following operations:
  - a. Supporting the bottom of the switch, aligns the chassis rails with the slide rails on the rack posts.
  - b. Pushes the switch slowly to slide the chassis rails along the slide rails until the mounting brackets are flush with the rack posts.
6. Another person uses screws (user-supplied) to attach the mounting brackets to the rack.

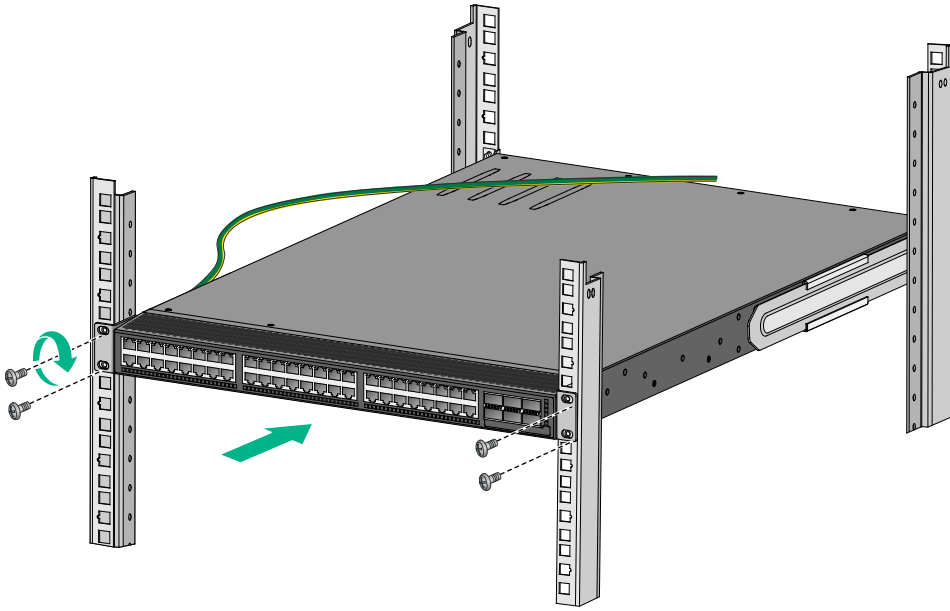
To secure the switch in the rack, make sure the front ends of the slide rails reach out of the chassis rails.

The rack-mounting procedures are the same for the HPE 5940 48SFP+ 6QSFP28, HPE 5940 48XGT 6QSFP28, HPE 5940 48XGT 6QSFP+, HPE 5940 48SFP+ 6QSFP+, and HPE 5940 32QSFP+ switches. The following figures use the HPE 5940 48XGT 6QSFP+ switch as an example.

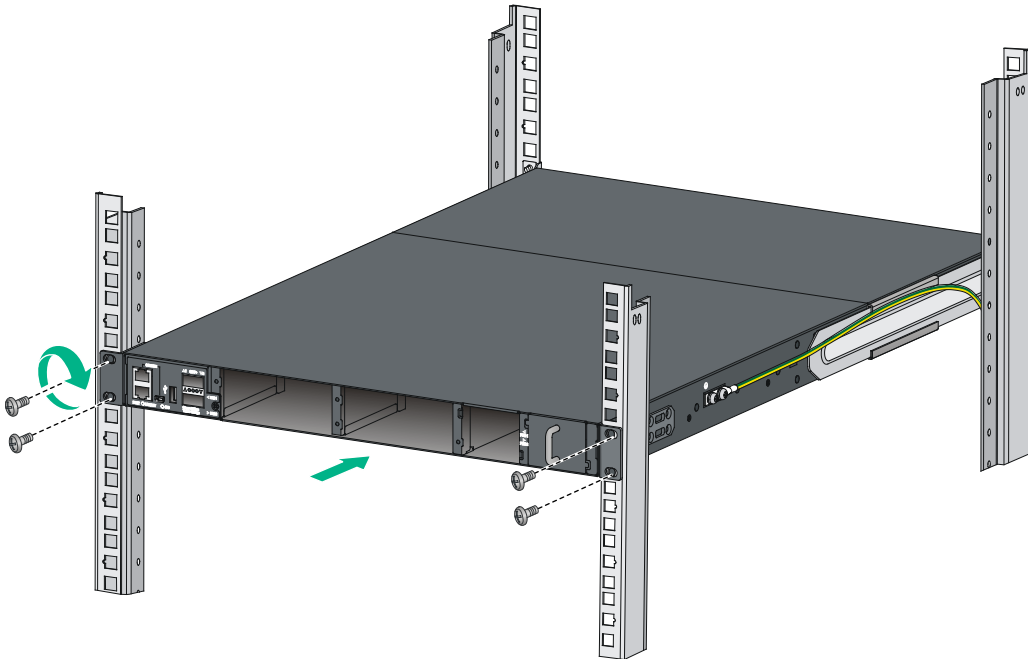
**Figure 20 Mounting the HPE 5940 48XGT 6QSFP+, switch in the rack (power supply-side mounting position for the mounting brackets)**



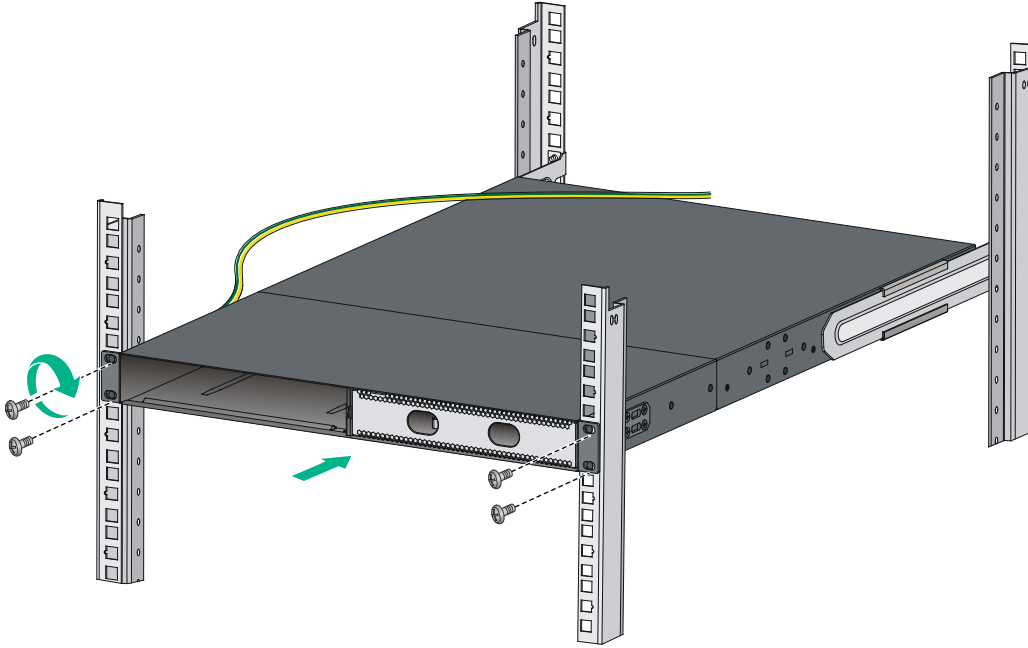
**Figure 21 Mounting the HPE 5940 48XGT 6QSFP+, switch in the rack (network port-side mounting position for the mounting brackets)**



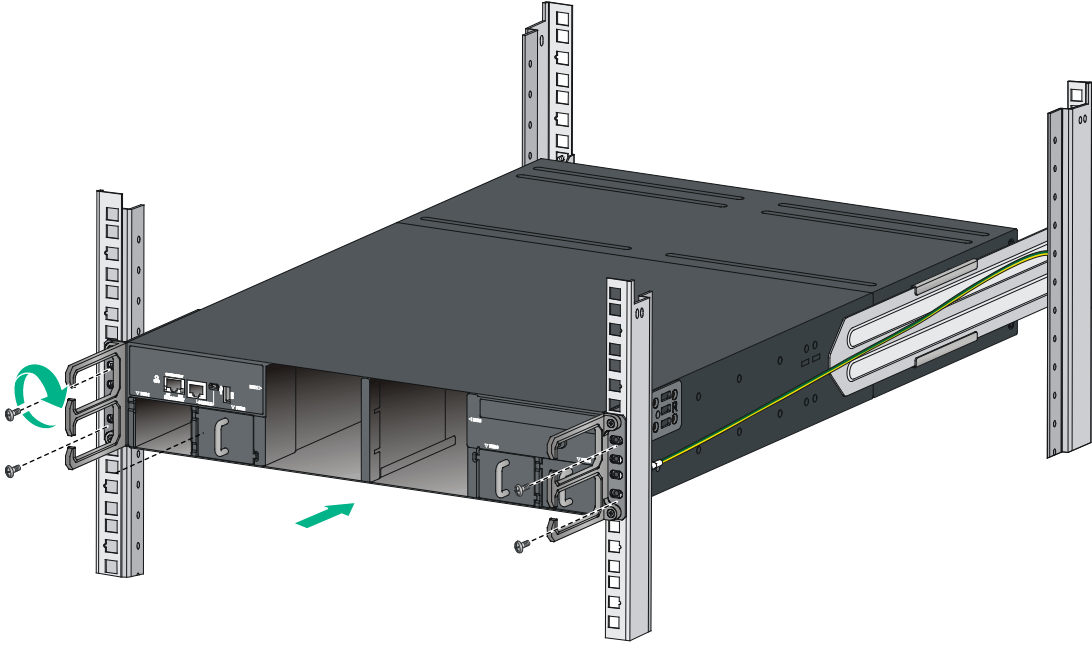
**Figure 22 Mounting the HPE 5940 2-slot switch in the rack (power module-side mounting position for the mounting brackets)**



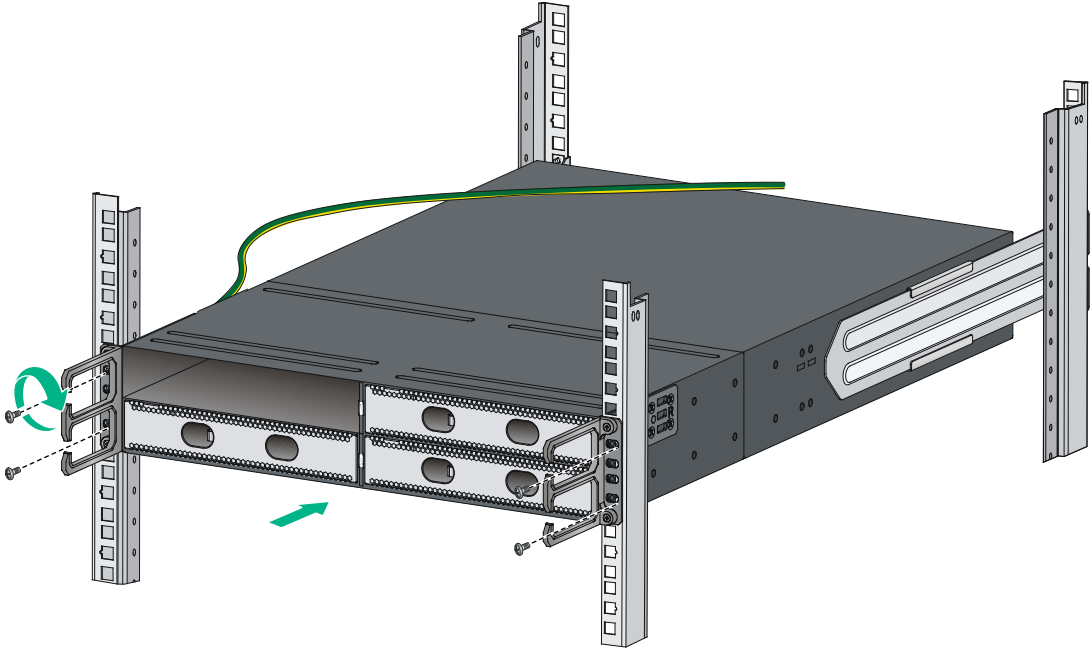
**Figure 23 Mounting the HPE 5940 2-slot switch in the rack (network port-side mounting position for the mounting brackets)**



**Figure 24 Mounting the HPE 5940 4-slot switch in the rack (power module-side mounting position for the mounting brackets)**



**Figure 25 Mounting the HEP 5940 4-slot switch in the rack (network port-side mounting position for the mounting brackets)**



**NOTE:**

To rack-mount the HEP 5940 4-slot switch by using 2U high mounting brackets and slide rails, use two screws and two cage nuts to attach each mounting bracket to the rack. Determine the screw installation positions based on the distances between the square holes on the rack posts. The screw installation positions in [Figure 24](#) and [Figure 25](#) are for illustration only.



# Grounding the switch

---

**⚠ WARNING!**

Correctly connecting the switch grounding cable is crucial to lightning protection and EMI protection.

The power input end of the switch has a noise filter, whose central ground is directly connected to the chassis to form the chassis ground (commonly known as PGND). You must securely connect this chassis ground to the earth so the faradism and leakage electricity can be safely released to the earth to minimize EMI susceptibility of the switch.

You can ground a switch by using a grounding strip at the installation site or the AC power cord connected to the switch.

---

**NOTE:**

The power and grounding terminals in this section are for illustration only.

---

## Grounding the switch with a grounding strip

---

**⚠ WARNING!**

Connect the grounding cable to the grounding system in the equipment room. Do not connect it to a fire main or lightning rod.

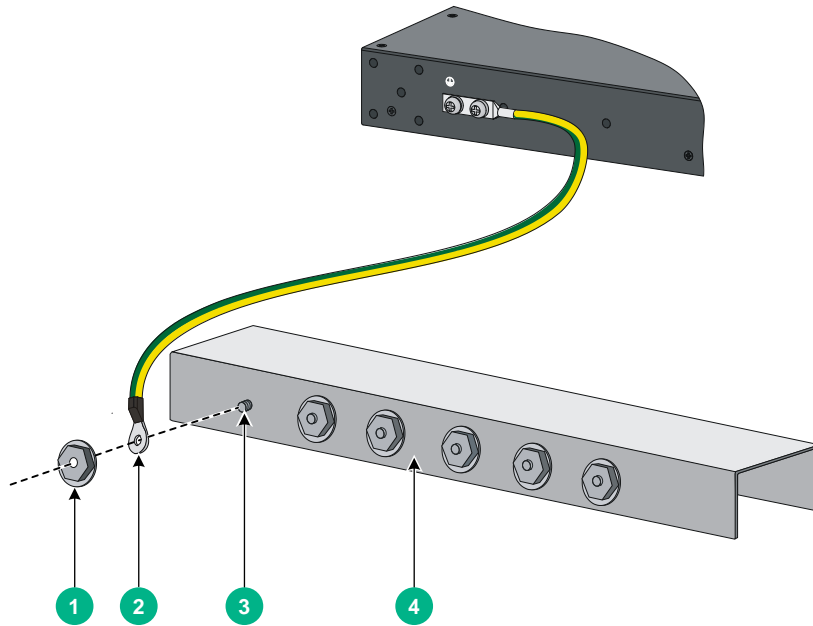
---

If a grounding strip is available at the installation site, connect the grounding cable to the grounding strip.

To connect the grounding cable:

1. Attach the two-hole grounding lug at one end of the grounding cable to a grounding point on the switch chassis. For more information, see "[Connecting the grounding cable to the chassis.](#)"
2. Remove the hex nut of a grounding post on the grounding strip.
3. Attach the ring terminal at the other end of the grounding cable to the grounding post on the grounding strip, and secure the ring terminal to the grounding post with the hex nut.

**Figure 26 Connecting the grounding cable to a grounding strip**



(1) Hex nut

(2) Ring terminal

(3) Grounding post

(4) Grounding strip

As a best practice, use the primary grounding point or auxiliary grounding point 1 on the switch, because the grounding cable and grounding screw provided with the switch are applicable only to these two grounding points.

To use auxiliary grounding point 2, prepare a grounding cable yourself. The connection method is the same as connecting to the other two grounding points.

## Grounding the switch by using the AC power cord

If the installation site has no grounding strips, you can ground an AC-powered switch through the protective earth (PE) wire of the power cord, but must make sure:

- The power cord has a PE terminal.
- The ground contact in the power outlet is securely connected to the ground in the power distribution room or on the AC transformer side.
- The power cord is securely connected to the power outlet.

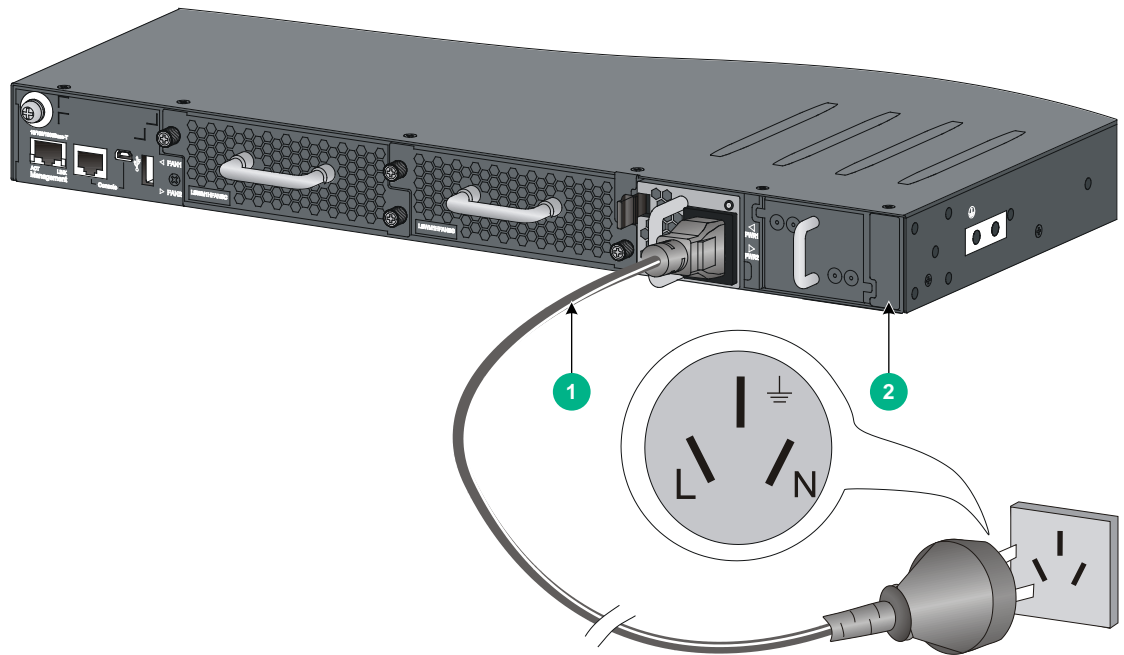
---

### **NOTE:**

If the ground contact in the power outlet is not connected to the ground, report the problem and reconstruct the grounding system.

---

**Figure 27 Grounding through the PE wire of the AC power cord**



**NOTE:**

To guarantee the grounding effect, use the grounding cable provided with the switch to connect to the grounding strip in the equipment room as long as possible.

## Installing/removing a fan tray

Follow these guidelines when you install or remove a fan tray:

- Do not power on the switch when the switch has no fan trays installed.
- You must install two fan trays of the same model for the switch.
- Do not keep operating the system with one failed fan tray.
- Make sure all slots have a module or filler panel installed when the switch is operating.
- When two fan trays fail during switch operation:
  - For an HPE 5940 32QSFP+ or HPE 5940 2-slot switch, finish replacing the fan trays within 2 minutes.
  - For an HPE 5940 48SFP+ 6QSFP+, HPE 5940 48XGT 6QSFP+, HPE 5940 48SFP+ 6QSFP28, HPE 5940 48XGT 6QSFP28, or HPE 5940 4-slot switch, finish replacing the fan trays within 1 minute.

## Installing a fan tray

**△ CAUTION:**

To prevent damage to the fan tray or the connectors on the backplane, insert the fan tray gently. If you encounter a hard resistance while inserting the fan tray, pull out the fan tray and insert it again.

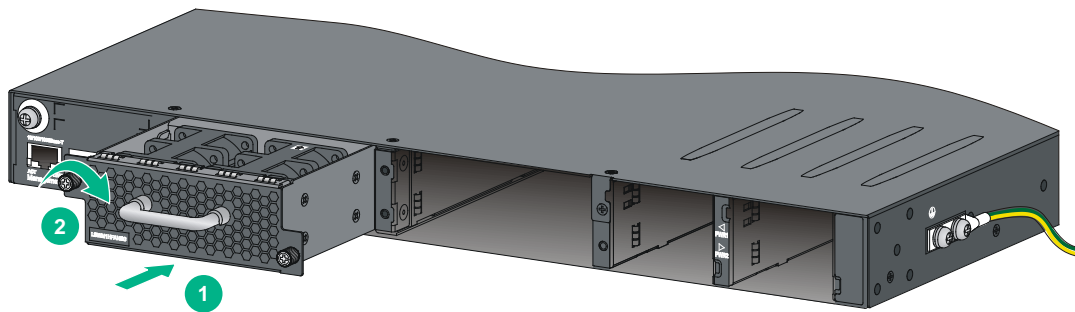
Select appropriate fan trays as needed. For the optional fan trays and their specifications, see "Fan trays."

### Installing an LSWM1FANSC/LSWM1FANSCB/LSWM1HFANSC/LSWM1HFANSCB fan tray

1. Wear an ESD wrist strap and make sure it makes good skin contact and is reliably grounded.
2. Unpack the fan tray and verify that the fan tray model is correct.
3. Grasp the handle of the fan tray with one hand and support the fan tray bottom with the other, and slide the fan tray along the guide rails into the slot until the fan tray seats in the slot and has a firm contact with the backplane (see callout 1 in [Figure 28](#)).
4. Fasten the captive screw on the fan tray with a Philips screwdriver until the fan tray is securely attached in the chassis (see callout 2 in [Figure 28](#)).

If the captive screw cannot be tightly fastened, verify the installation of the fan tray.

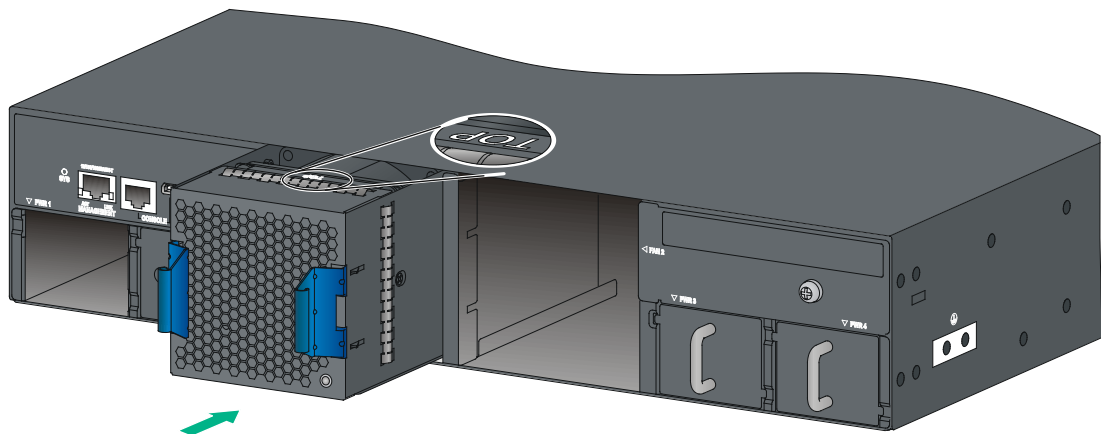
**Figure 28** Installing an LSWM1HFANSC fan tray for an HPE 5940 32QSFP+ switch



### Installing an LSWM1BFANSC/LSWM1BFANSCB fan tray

1. Wear an ESD wrist strap and make sure it makes good skin contact and is reliably grounded.
2. Unpack the fan tray and verify that the fan tray model is correct.
3. Orient the fan tray with the "TOP" mark on the top. Grasp the handle of the fan tray with one hand and support the fan tray bottom with the other, and slide the fan tray along the guide rails into the slot until the fan tray is fully seated in the slot and has a firm contact with the backplane.

**Figure 29** Installing an LSWM1BFANSC/LSWM1BFANSCB fan tray



## Removing a fan tray

### **⚠ WARNING!**

- Ensure electricity safety and never touch the rotating fans when you hot-swap a fan tray.
- To prevent an unbalanced fan from causing loud noise, do not touch the fans, even if they are not rotating.

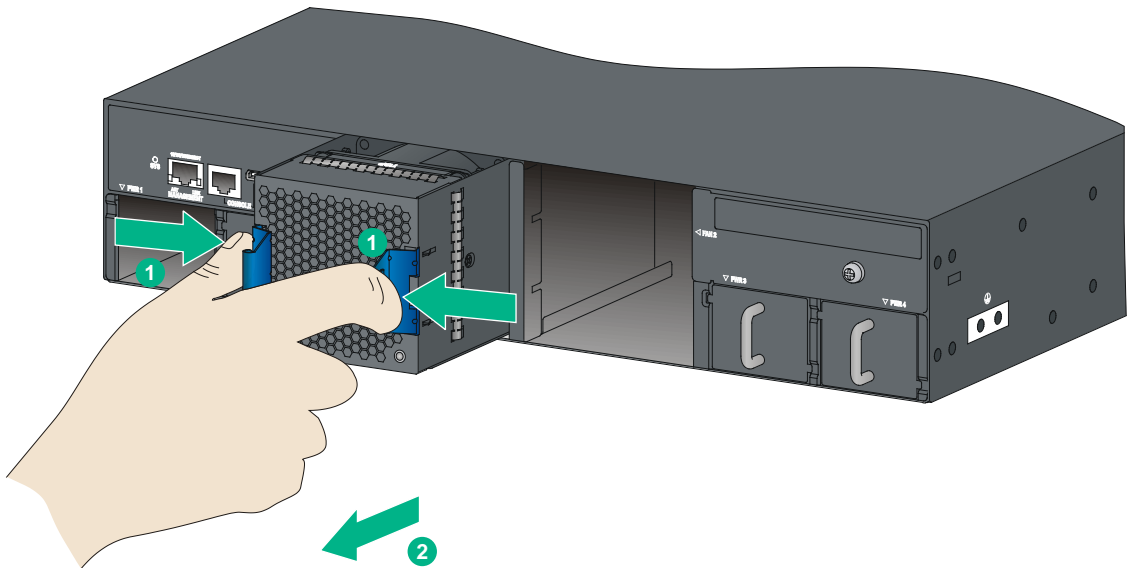
### **Removing an LSWM1FANSC/LSWM1FANSCB/LSWM1HFANSC/LSWM1HFANSCB fan tray**

1. Wear an ESD wrist strap and make sure it makes good skin contact and is reliably grounded.
2. Loosen the captive screw of the fan tray with a Philips screwdriver until it is fully disengaged from the switch chassis.
3. Grasp the handle of the fan tray with one hand and pull the fan tray part way out of the slot. Support the fan tray bottom with the other hand, and pull the fan tray slowly along the guide rails out of the slot.
4. Place the removed fan tray in an antistatic bag.

### **Removing an LSWM1BFANSC/LSWM1BFANSCB fan tray**

1. Wear an ESD wrist strap and make sure it makes good skin contact and is reliably grounded.
2. Grasp the fan tray handle with one hand to pull the fan tray part way out. Support the fan tray bottom with the other and pull out the fan tray slowly along the guide rails.
3. Place the removed fan tray in an antistatic bag.

**Figure 30 Removing an LSWE1BFANSC/LSWE1BFANSCB fan tray**



## Installing/removing a power supply

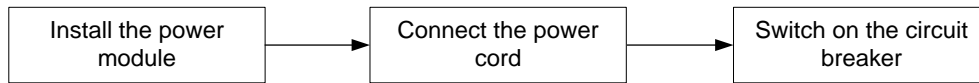
### **⚠ WARNING!**

- In power redundancy mode, you can replace a power supply without powering off the switch but must strictly follow the installation and procedures in [Figure 31](#) and [Figure 32](#) to avoid any bodily injury or damage to the switch.
- Provide a separate circuit breaker for each power supply.

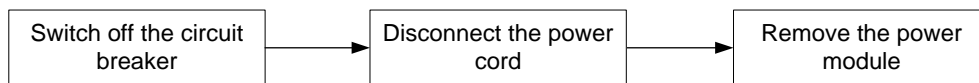
The switch comes with the power supply slots empty and filler panels for the power supply slots as accessories.

For more information about the power supplies available for the switches, see "[Power supplies](#)".

#### Figure 31 Installation procedure



#### Figure 32 Removal procedure



## Installing a power supply

### ⚠ CAUTION:

- Follow the forward inertia of the power supply when inserting it into the chassis, and make sure the power supply has firm contact with the connectors on the backplane.
- To prevent damage to the connectors inside the switch chassis, insert the power supply gently. If you encounter a hard resistance while inserting the power supply, pull out the power supply and insert it again.
- Install filler panels in the empty power supply slots for good ventilation of the switch.

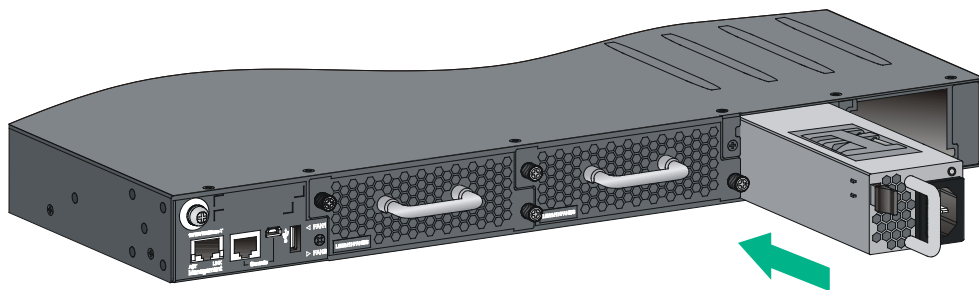
The power supply installation procedures are the same for all HPE FlexFabric 5940 switches. This section uses the HPE 5940 32QSFP+ switch as an example.

To install a power supply:

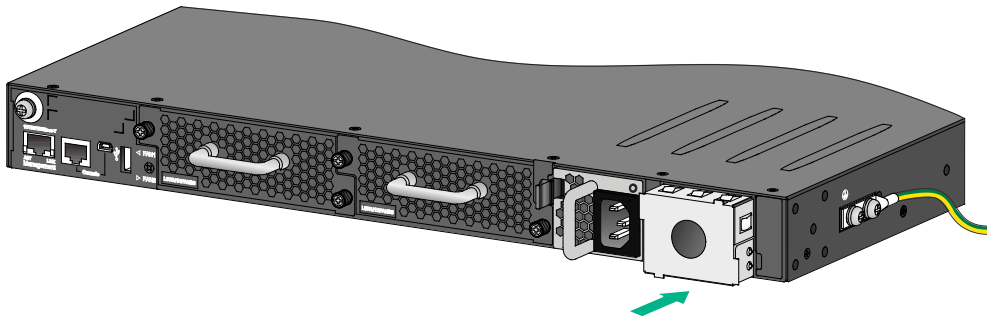
1. Wear an ESD wrist strap and make sure it makes good skin contact and is reliably grounded.
2. Unpack the power supply and verify that the power supply model is correct.
3. Correctly orient the power supply with the power supply slot (see [Figure 33](#)), grasp the handle of the power supply with one hand and support its bottom with the other, and slide the power supply slowly along the guide rails into the slot.

The slot is foolproof. If you cannot insert the power supply into the slot, re-orient the power supply rather than use excessive force to push it in.

#### Figure 33 Installing a power supply



**Figure 34 Installing a filler panel in a power supply slot**



## Removing a power supply

### **⚠ CAUTION:**

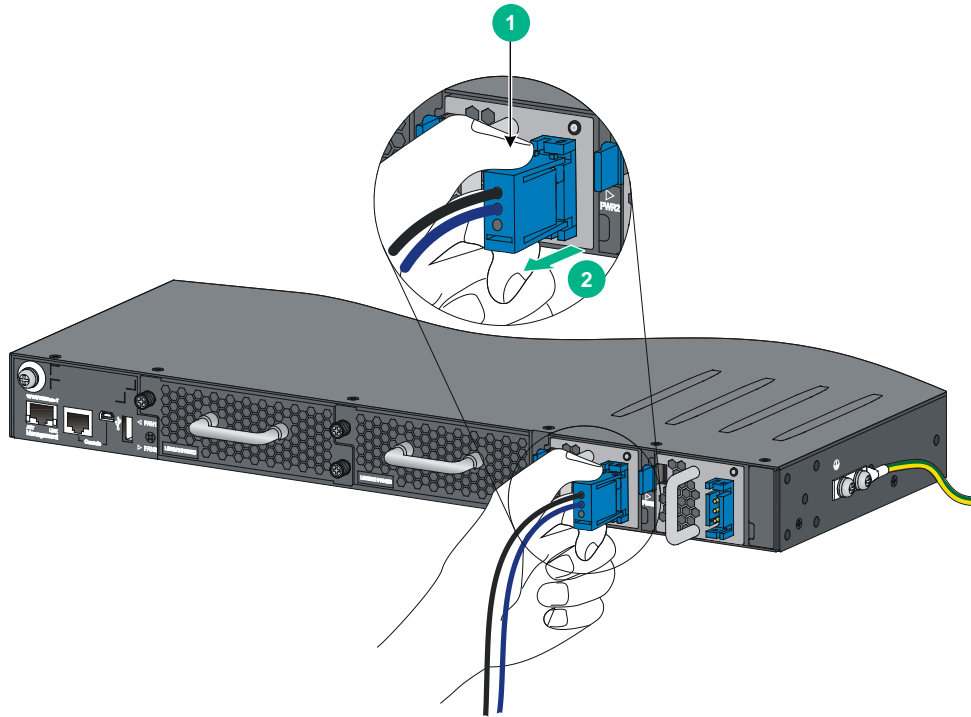
- When an HPE 5940 48SFP+ 6QSFP28, HPE 5940 48XGT 6QSFP28, HPE 5940 48XGT 6QSFP+, HPE 5940 48SFP+ 6QSFP+, HPE 5940 32QSFP+, or HPE 5940 2-slot switch has two power supplies in 1+1 redundancy mode, removing one power supply does not affect the operation of the switch. When the switch has only one power supply installed, removing the power supply powers off the switch.
- When an HPE 5940 4-slot switch has four power modules in 2+2 redundancy mode, removing one or two power modules does not affect the operation of the switch. When the switch has only two power module installed, removing a power module might power off the switch or cause power insufficiency.
- The power cord color code scheme in [Figure 35](#) is for illustration only. The cable delivered for your country or region might use a different color scheme. When you connect the power cord, always identify the polarity symbol on its wires.

The power supply removing procedures are the same for all HPE FlexFabric 5940 switches. This section uses the HPE 5940 32QSFP+ switch as an example:

To remove a power supply:

1. Wear an ESD wrist strap and make sure it makes good skin contact and is reliably grounded.
2. Squeeze the tabs on the power cord connector with your thumb and forefinger, and pull the connector out to remove the power cord, as shown in [Figure 35](#).
3. Hold the handle on the power supply with one hand, pivot the latch on the power supply to the right with your thumb, and pull the power supply part way out of the slot, as shown in [Figure 36](#).
4. Supporting the power supply bottom with one hand, slowly pull the power supply out with the other hand.
5. Put away the removed power supply in an antistatic bag for future use.

**Figure 35 Removing the DC power cord**



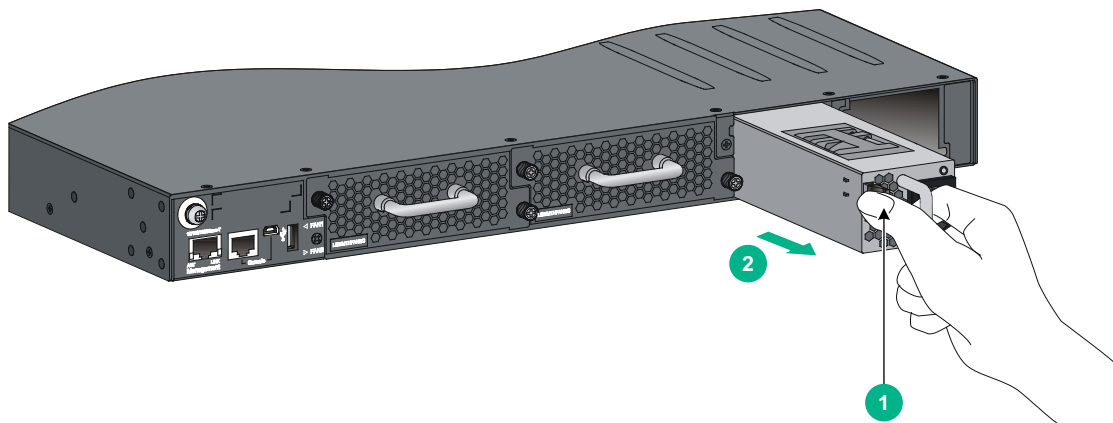
---

(1) Press the tabs on the power cord connector with your thumb and forefinger

(2) Pull the power cord connector out

---

**Figure 36 Removing the power supply**



---

(1) Pivot the latch to the right with your thumb

(2) Pull the power supply out

---

## Connecting the power cord

**⚠ WARNING!**

Provide a circuit breaker for each power input. When you connect a power cord, make sure the circuit breaker is switched off.

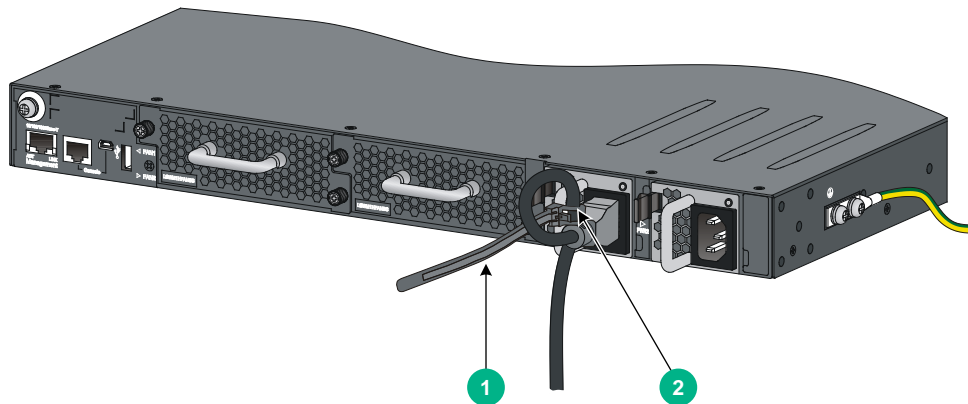
---



## Connecting an AC power cord

1. Insert the female connector of the AC power cord supplied with the power supply into the power receptacle on the power supply.
2. Use a cable tie to secure the power cord to the handle of the power supply, as shown in [Figure 37](#).
3. Connect the other end of the power cord to an AC power outlet.

**Figure 37 Connecting the 300W AC or 650W AC power supply**



---

(1) Cable tie

(2) Tighten the cable tie to secure the power cord to the handle of the power supply

---

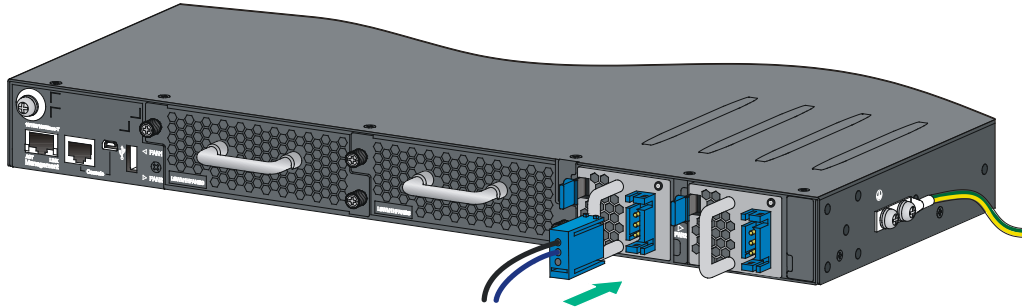
## Connecting a DC power cord

### ⚠ CAUTION:

The power cord color code scheme in [Figure 38](#) is for illustration only. The cable delivered for your country or region might use a different color scheme. When you connect the power cord, always identify the polarity symbol on its wires.

1. Unpack the DC power cord, identify the plug for connecting to the power supply, orient the plug with the power receptacle on the power supply, and insert the plug into the receptacle (see [Figure 38](#)).  
The receptacle is foolproof. If you cannot insert the plug into the receptacle, re-orient the plug rather than use excessive force to push it in.
2. Use a cable tie to secure the power cord to the handle of the power supply, as shown in [Figure 37](#).
3. Connect the other ends of the wires to the DC power source wiring terminals, with the negative wire (– or L–) to the negative terminal (–) and the positive wire (+ or M/N) to the positive terminal (+).

Figure 38 Connecting the 300W DC or 650W DC power supply



## Installing/removing an interface module

### ⚠ CAUTION:

When you install or remove an interface module, follow these guidelines:

- Never touch the components on the interface module surface.
- Do not use excessive force.

The HPE 5940 2-slot switch provides two interface module slots. The HPE 5940 4-slot switch provides four interface module slots. For the available interface modules, see "[Appendix B FRUs and compatibility matrixes](#)."

The interface module installation and removal procedures are the same. This section uses the LSWM18QC interface module as an example.

### Installing an interface module

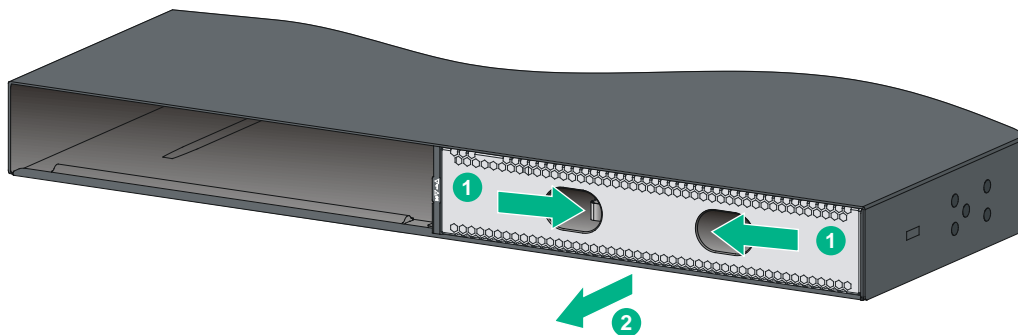
1. Wear an ESD wrist strap and make sure the wrist strap makes good skin contact and is reliably grounded.
2. (Optional.) If the target interface module slot has a filler panel installed, remove the filler panel.

[Figure 39](#) uses the HPE 5940 2-slot switch as an example.

To remove a filler panel from an interface module slot:

- a. Use your thumb and forefinger to hold the filler panel through the two holes.
- b. Push right the metal tab in the left hole and pull out the filler panel along the guide rails.

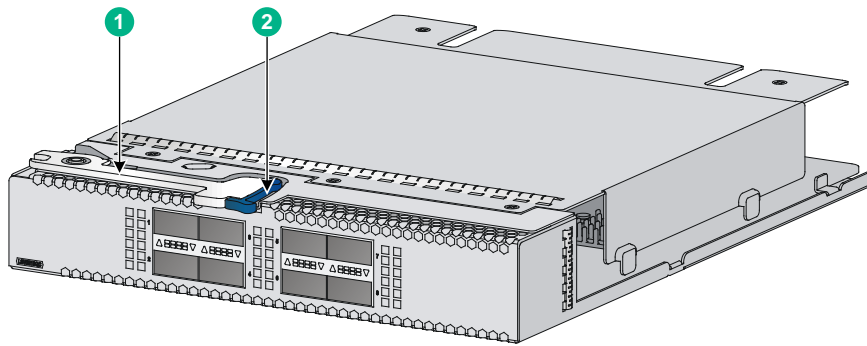
Figure 39 Removing the filler panel



Keep the removed filler panel secure for future use.

3. Unpack the interface module.

**Figure 40 LSWM18QC interface module**



---

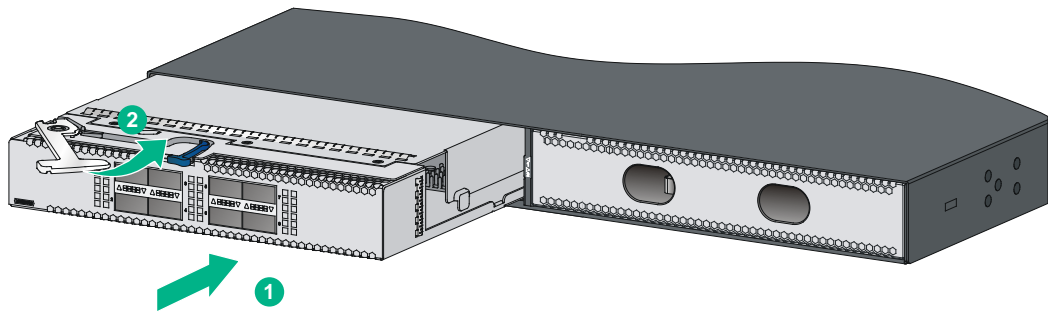
(1) Ejector lever

(2) Latch

---

4. Press the latch on the interface module to release the ejector lever.
5. Insert the interface module slowly into the slot along the guide rails, as shown by callout 1 in [Figure 41](#).
6. Rotate inward the ejector lever as shown by callout 2 in [Figure 41](#) until the latch locks the ejector lever in place.

**Figure 41 Installing an LSWM18QC interface module**



## Removing an interface module

---

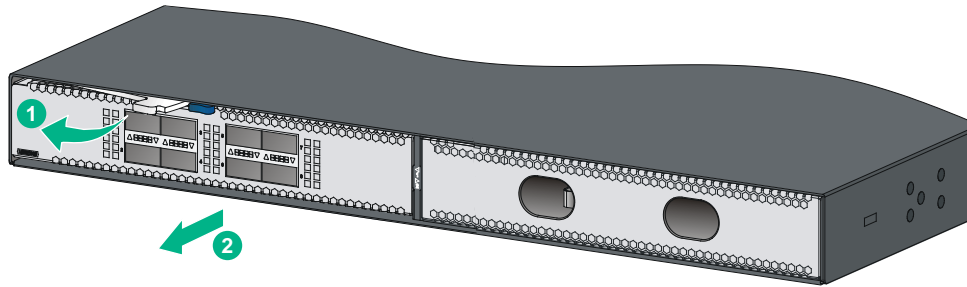
**CAUTION:**

- Before you remove an interface module, remove the cables from it to avoid cable damage.
  - If you are not to install a new interface module after removing the original one, install the filler panel in the slot to prevent dust and ensure good ventilation in the device.
- 

To remove an interface module:

1. Prepare an anti-static bag.
2. Wear an ESD wrist strap and make sure the wrist strap makes good skin contact and is reliably grounded.
3. Press the latch to release the ejector lever.
4. Rotate outward the ejector lever as shown by callout 1 in [Figure 42](#).
5. Pull out the interface module slowly out of the interface module slot, as shown by callout 2 in [Figure 42](#).
6. Place the removed interface module in the anti-static bag.

Figure 42 Removing an LSWM18QC interface module



## Verifying the installation

After you complete the installation, verify that:

- There is enough space for heat dissipation around the switch, and the rack is stable.
- The grounding cable is securely connected.
- The correct power source is used.
- The power cords are correctly connected.
- All the interface cables are cabled indoors. If any cable is routed outdoors, verify that the socket strip with lightning protection and lightning arresters for network ports have been correctly connected.

# Accessing the switch for the first time

## Setting up the configuration environment

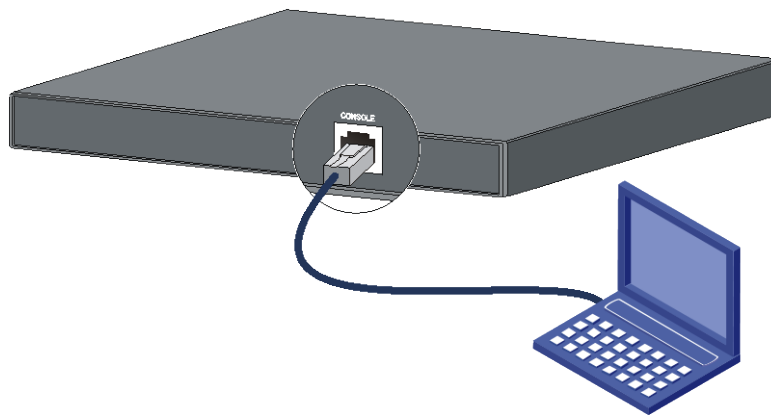
The switch supports the following ways to connect the configuration terminal:

- Through the console port by using the serial console cable  
The switch comes with the serial console cable. This way is preferred.
- Through the Mini USB console port by using the user-supplied USB mini console cable

Do not use the two ways together on the same switch.

The example uses a console cable to connect a console terminal (PC) to the serial console port on the switch.

**Figure 43 Connecting the serial console port to a terminal**

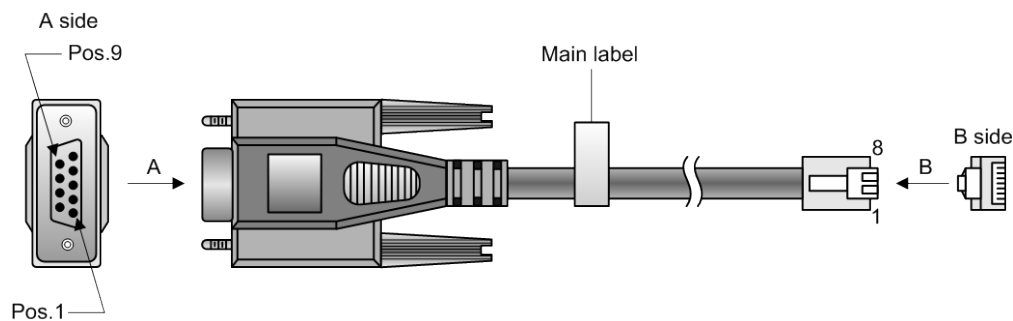


## Connecting the console cable

### Serial console cable

A serial console cable is an 8-core cable, with a crimped RJ-45 connector at one end for connecting to the serial console port of the switch, and a DB-9 female connector at the other end for connecting to the serial port on the console terminal.

**Figure 44 Serial console cable**



**Table 7 Serial console cable pinout**

<b>RJ-45</b>	<b>Signal</b>	<b>DB-9</b>	<b>Signal</b>
1	RTS	8	CTS
2	DTR	6	DSR
3	TXD	2	RXD
4	SG	5	SG
5	SG	5	SG
6	RXD	3	TXD
7	DSR	4	DTR
8	CTS	7	RTS

## USB mini console cable

A USB mini console cable has a USB mini-Type B connector at one end to connect to the Mini USB console port of the switch, and a standard USB Type A connector at the other end to connect to the USB port on the configuration terminal.

## Connection procedure

To connect a terminal (for example, a PC) to the switch by using the serial console cable:

1. Plug the DB-9 female connector of the serial console cable to the serial port of the PC.
2. Connect the RJ-45 connector to the serial console port of the switch.

---

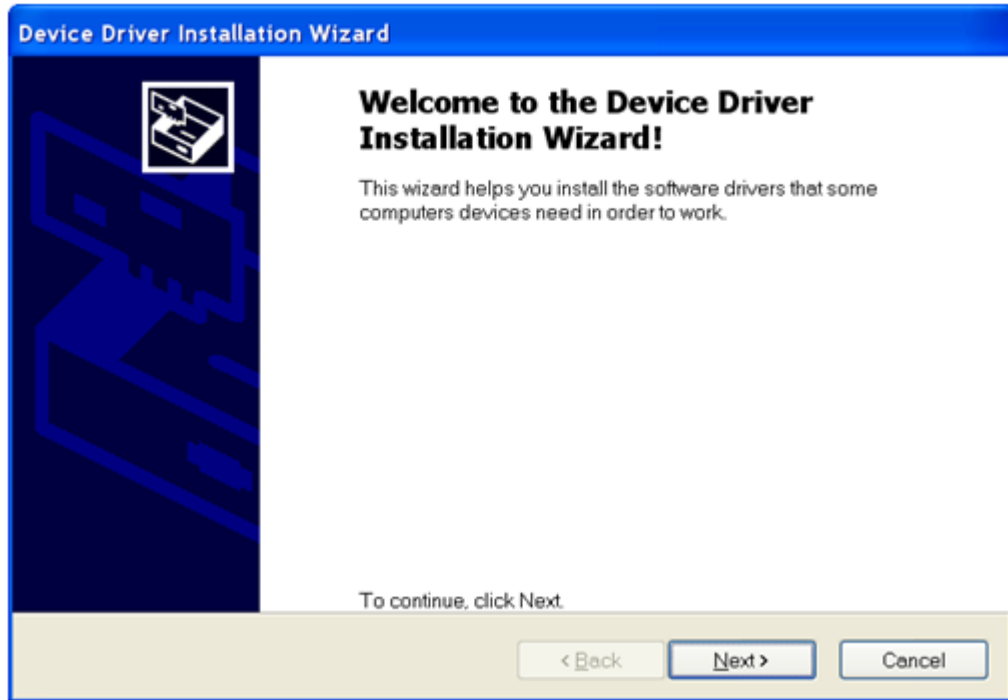
### NOTE:

- Identify the mark on the console port and make sure you are connecting to the correct port.
  - The serial ports on PCs do not support hot swapping. If the switch has been powered on, connect the serial console cable to the PC before connecting to the switch, and when you disconnect the cable, first disconnect from the switch.
- 

To connect to the configuration terminal through the USB mini console cable:

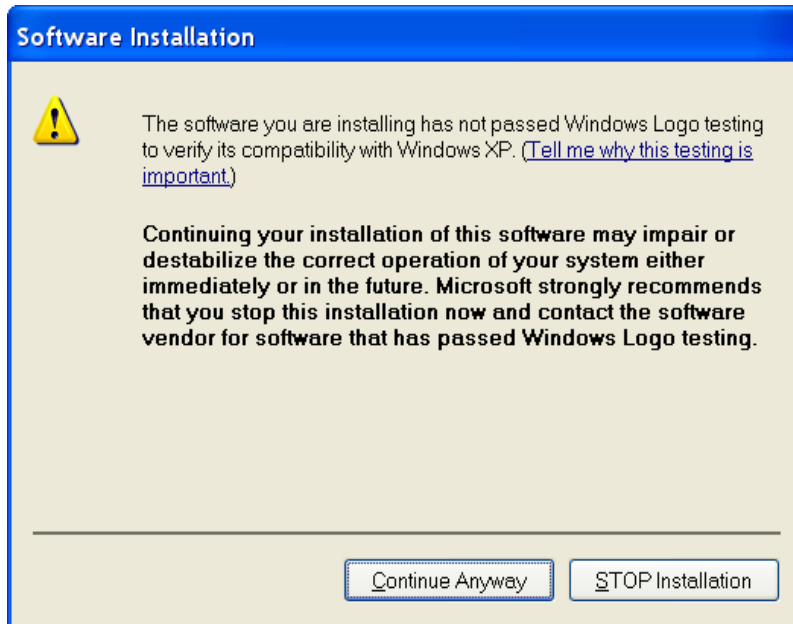
1. Connect the standard USB Type A connector to the USB port of the configuration terminal.
2. Connect the USB mini Type B connector to the Mini USB console port of the switch.
3. Click the following link, or copy it to the address bar on the browser to log in to download page of the USB console driver, and download the driver.
4. Select a driver program according to the operating system you use:
  - **XR21V1410\_XR21B1411\_Windows\_Ver1840\_x86\_Installer.EXE**—32-bit operating system.
  - **XR21V1410\_XR21B1411\_Windows\_Ver1840\_x64\_Installer.EXE**—64-bit operating system.
5. Click **Next** on the installation wizard.

Figure 45 Device Driver Installation Wizard



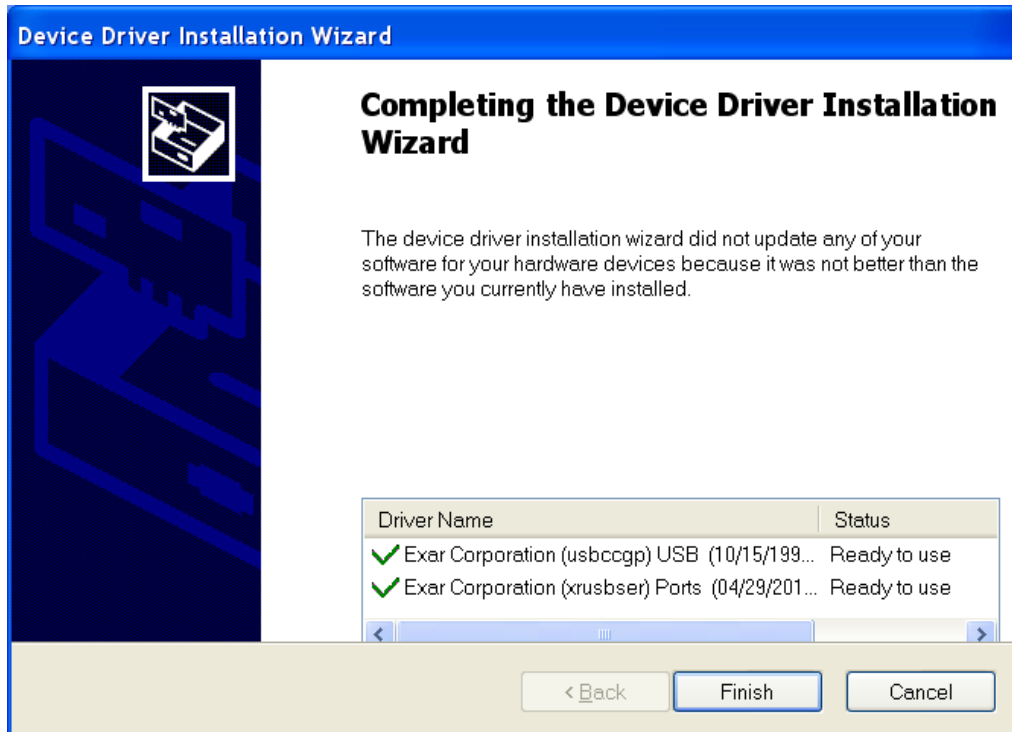
6. Click **Continue Anyway** if the following dialog box appears.

Figure 46 Software Installation



7. Click **Finish**.

Figure 47 Completing the device driver installation wizard



## Setting terminal parameters

To configure and manage the switch through the console port, you must run a terminal emulator program, TeraTermPro or PuTTY, on your configuration terminal. You can use the emulator program to connect a network device, a Telnet site, or an SSH site. For more information about the terminal emulator programs, see the user guides for these programs

The following are the required terminal settings:

- **Bits per second**—9600
- **Data bits**—8
- **Stop bits**—1
- **Parity**—None
- **Flow control**—None

## Powering on the switch

Before powering on the switch, verify that the following conditions are met:

- The power cord is correctly connected.
- The input power voltage meets the requirement of the switch.
- The console cable is correctly connected.
- The configuration terminal (a PC, for example) has started, and its serial port settings are consistent with the console port settings on the switch.

Power on the switch. During the startup process, you can access Boot ROM menus to perform tasks such as software upgrade and file management. The Boot ROM interface and menu options differ



with software versions. For more information about Boot ROM menu options, see the software-matching release notes for the device.

After the startup completes, you can access the CLI to configure the switch.

For more information about the configuration commands and CLI, see *HPE FlexFabric 5940 Switch Series Configuration Guides* and *HPE FlexFabric 5940 Switch Series Command References*.

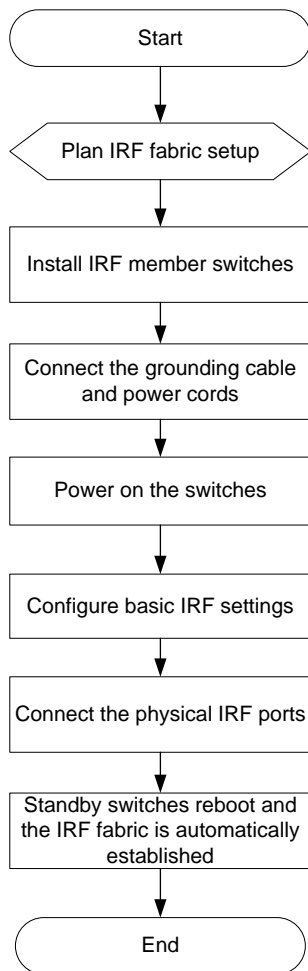
# Setting up an IRF fabric

You can use IRF technology to connect and virtualize HPE FlexFabric 5940 switches into a large virtual switch called an "IRF fabric" for flattened network topology, and high availability, scalability, and manageability.

To set up IRF links between two switches, use the 10-GE, 40-GE, or 100-GE ports.

## IRF fabric setup flowchart

Figure 48 IRF fabric setup flowchart



To set up an IRF fabric:

Step	Description
1. Plan IRF fabric setup.	Plan the installation site and IRF fabric setup parameters: <ul style="list-style-type: none"> <li>• <a href="#">Planning IRF fabric size and the installation site</a></li> <li>• <a href="#">Identifying the master switch and planning IRF member IDs</a></li> <li>• <a href="#">Planning IRF topology and connections</a></li> <li>• <a href="#">Identifying physical IRF ports on the member switches</a></li> <li>• <a href="#">Planning the cabling scheme</a></li> </ul>

Step	Description
2. Install IRF member switches.	See <a href="#">"Installing the switch in a 19-inch rack"</a> .
3. Connect ground wires and power cords.	See <a href="#">"Grounding the switch"</a> and <a href="#">"Connecting the power cord."</a>
4. Power on the switches.	N/A
5. Configure basic IRF settings.	See <i>HPE FlexFabric 5940 Switch Series IRF Configuration Guide</i> .
6. Connect the physical IRF ports.	Connect the physical IRF ports on switches. Use SFP+, QSFP+, or QSFP28 transceiver modules and fibers for long-distance connection. Use twisted pair cables or SFP+, QSFP+, or QSFP28 cables for short-distance connection.  All switches except the master switch automatically reboot, and the IRF fabric is established.

## Planning IRF fabric setup

This section describes issues that an IRF fabric setup plan must cover.

### Planning IRF fabric size and the installation site

Choose switch models and identify the number of required IRF member switches, depending on the user density and upstream bandwidth requirements. The switching capacity of an IRF fabric equals the total switching capacities of all member switches.

Plan the installation site depending on your network solution as follows:

- Place all IRF member switches in one rack for centralized high-density access.
- Distribute the IRF member switches in different racks to implement the top-of-rack (ToR) access solution for a data center.

As your business grows, you can plug *HPE FlexFabric 5940* switches into the IRF fabric to increase the switching capacity without any topology change or replacement.

### Identifying the master switch and planning IRF member IDs

Determine which switch you want to use as the master for managing all member switches in the IRF fabric. An IRF fabric has only one master switch. You configure and manage all member switches in the IRF fabric at the command line interface of the master switch.

---

#### NOTE:

IRF member switches will automatically elect a master. You can affect the election result by assigning a high member priority to the intended master switch. For more information about master election, see *HPE FlexFabric 5940 Switch Series IRF Configuration Guide*.

---

Prepare an IRF member ID assignment scheme. An IRF fabric uses member IDs to uniquely identify and manage its members, and you must assign each IRF member switch a unique member ID.

# Planning IRF topology and connections

You can create an IRF fabric in daisy chain topology, or more reliably, ring topology. In ring topology, the failure of one IRF link does not cause the IRF fabric to split as in daisy chain topology. Rather, the IRF fabric changes to a daisy chain topology without interrupting network services.

You connect the IRF member switches through IRF ports, the logical interfaces for the connections between IRF member switches. Each IRF member switch has two IRF ports: IRF-port 1 and IRF-port 2. To use an IRF port, you must bind at least one physical port to it.

When connecting two neighboring IRF member switches, you must connect the physical ports of IRF-port 1 on one switch to the physical ports of IRF-port 2 on the other switch.

The IRF port connections in the two figures are for illustration only, and more connection methods are available.

**Figure 49 IRF fabric in daisy chain topology**

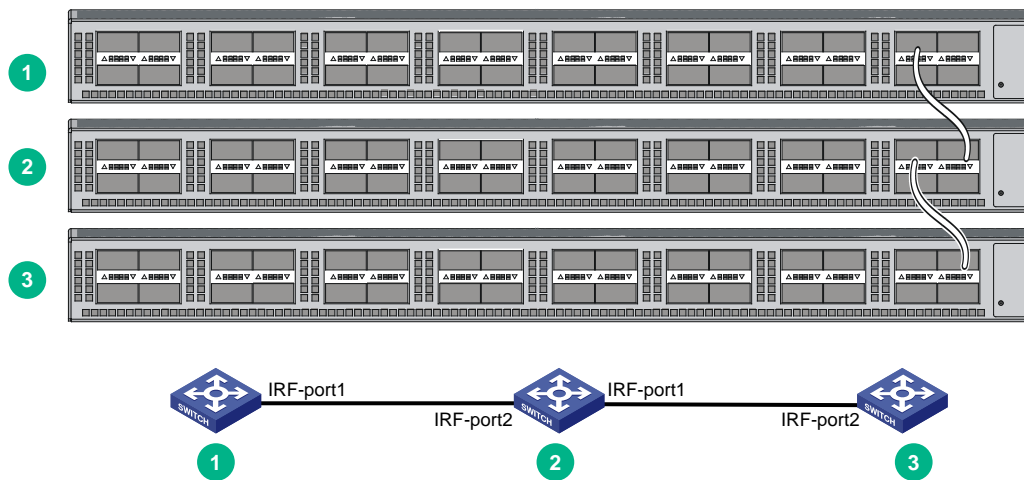
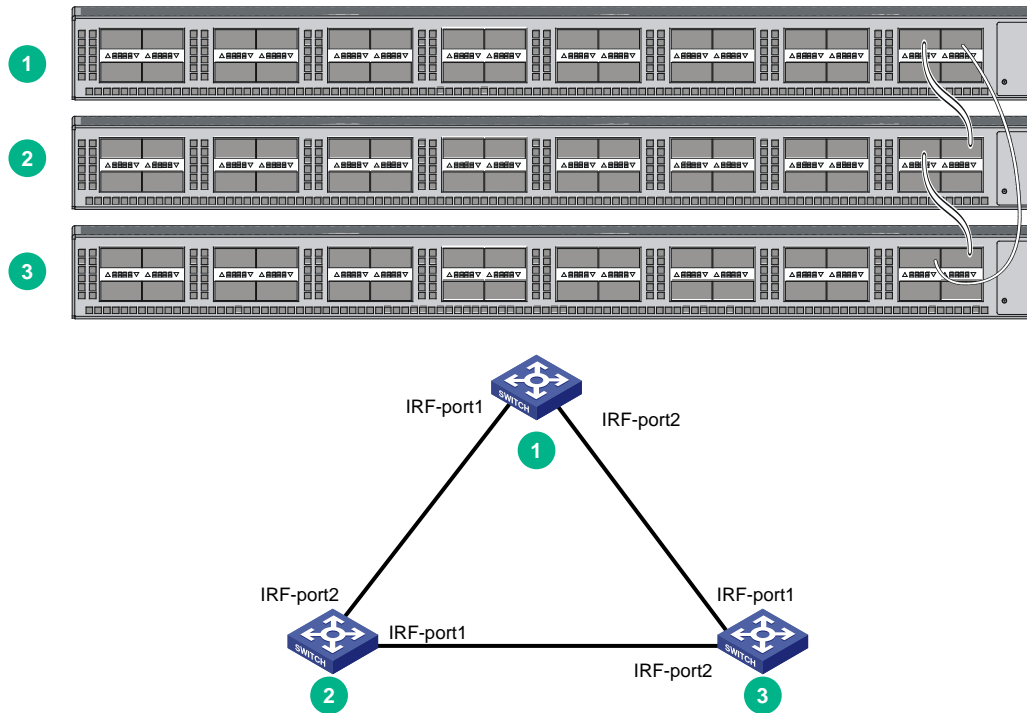


Figure 50 IRF fabric in ring topology



You can provide the following IRF physical connections between *HPE FlexFabric 5940* switches:

- 10-GE IRF physical connection by connecting 10GBase-T Ethernet ports or SFP+ ports.
- 40-GE IRF physical connection by connecting QSFP+ ports.
- 100-GE IRF physical connection by connecting QSFP28 ports.
- IRF physical connection by using a 40G QSFP+ to 4 x 10G SFP+ cable to connect a QSFP+ port and four SFP+ ports.

You can bind several ports to an IRF port for increased bandwidth and availability.

## Identifying physical IRF ports on the member switches

Identify the 10GBase-T Ethernet ports, SFP+ ports, QSFP+, and QSFP28 ports to be used for IRF connections on the member switches according to your topology and connection scheme.

All the 10GBase-T Ethernet ports, SFP+ ports, QSFP+ ports, and QSFP28 ports on the *HPE FlexFabric 5940* switch can be used for IRF connections.

## Planning the cabling scheme

You can use twisted pair cables, SFP+/QSFP+/QSFP28 cables, or SFP+/QSFP+/QSFP28 transceiver modules and optical fibers to connect the switches for IRF connections. If the IRF member switches are far away from one another, choose the SFP+/QSFP+/QSFP28 transceiver modules and optical fibers. If the IRF member switches are all in one equipment room, choose twisted pair cables or SFP+/QSFP+/QSFP28 cables. For more information about available transceiver modules and cables, see "[Appendix C Ports and LEDs.](#)"

The following subsections describe several IRF connection schemes recommended by Hewlett Packard Enterprise. All these schemes use a ring topology.

## Connecting the IRF member switches in one rack

Figure 51 shows an example for connecting four IRF member switches in a rack by using QSFP+ cables and QSFP+ transceiver modules and optical fibers. The switches in the ring topology (see Figure 52) are in the same order as connected in the rack.

Figure 51 Connecting the switches in one rack

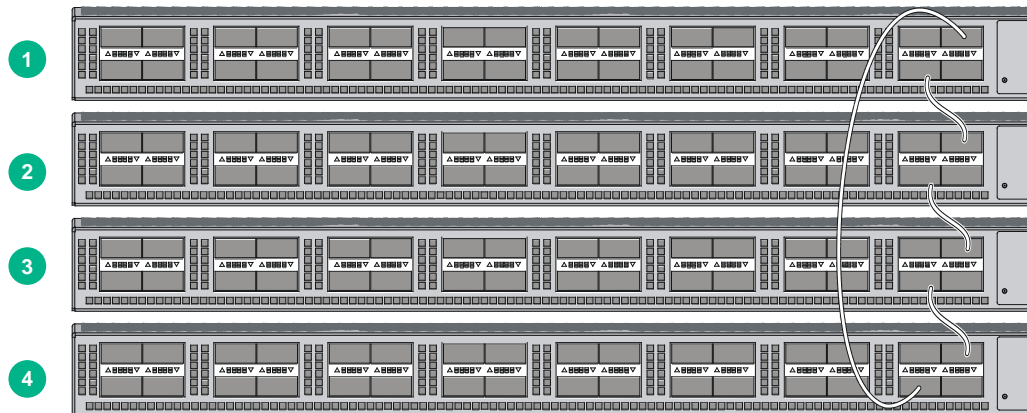
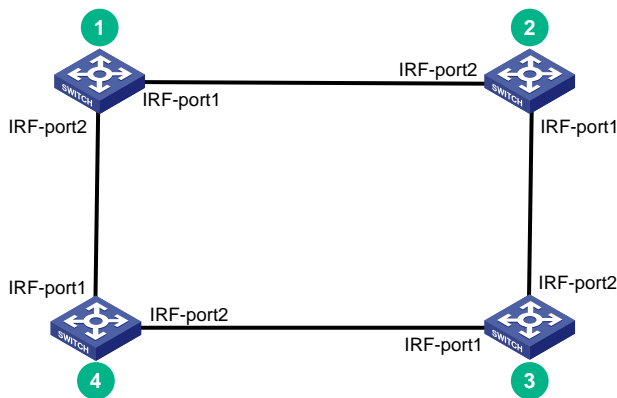


Figure 52 IRF fabric topology

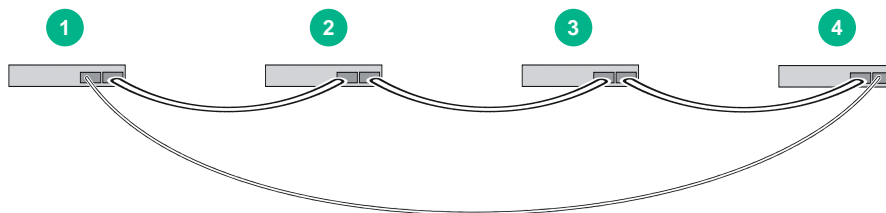


## Connecting the IRF member switches in a ToR solution

You can install IRF member switches in different racks side by side to deploy a top of rack (ToR) solution.

Figure 53 shows an example for connecting four top of rack IRF member switches by using QSFP+ cables and QSFP+ transceiver modules and optical fibers. The topology is the same as Figure 52.

Figure 53 ToR cabling



# Configuring basic IRF settings

After you install the IRF member switches, power on the switches, and log in to each IRF member switch (see *HPE FlexFabric 5940 Switch Series Fundamentals Configuration Guide*) to configure their member IDs, member priorities, and IRF port bindings.

Follow these guidelines when you configure the switches:

- Assign the master switch higher member priority than any other switch.
- Bind physical ports to IRF port 1 on one switch and to IRF port 2 on the other switch. You perform IRF port binding before or after connecting IRF physical ports depending on the software release.
- Execute the **display irf configuration** command to verify the basic IRF settings.

For more information about configuring basic IRF settings, see *HPE FlexFabric 5940 Switch Series IRF Configuration Guide*.

## Connecting the physical IRF ports

### CAUTION:

Wear an ESD wrist strap when you connect cables or transceiver modules and optical fibers. For more information, see the installation guide for the transceiver modules.

Use cables or transceiver modules and optical fibers to connect the IRF member switches as planned.

## Accessing the IRF fabric to verify the configuration

To verify the basic functionality of the IRF fabric after you finish configuring basic IRF settings and connecting IRF ports:

1. Log in to the IRF fabric through the console port of any member switch.
2. Create a Layer 3 interface, assign it an IP address, and make sure the IRF fabric and the remote network management station can reach each other.
3. Use Telnet or SNMP to access the IRF fabric from the network management station. (See *HPE FlexFabric 5940 Switch Series Fundamentals Configuration Guide*.)
4. Verify that you can manage all member switches as if they were one node.
5. Display the running status of the IRF fabric by using the commands in [Table 8](#).

**Table 8 Displaying and maintaining IRF configuration and running status**

Task	Command
Display information about the IRF fabric.	<b>display irf</b>
Display all members' IRF configurations.	<b>display irf configuration</b>
Display IRF fabric topology information.	<b>display irf topology</b>

### NOTE:

To avoid IP address collision and network problems, configure at least one multi-active detection (MAD) mechanism to detect the presence of multiple identical IRF fabrics and handle collisions. For more information about MAD detection, see *HPE FlexFabric 5940 Switch Series IRF Configuration Guide*.

# Maintenance and troubleshooting

## Power supply failure

### Symptom

The LEDs on a power supply are not green.

You can use the LEDs on the power supply to identify a power supply failure. For more information about the LEDs on a power supply, see *HPE 300W AC & 300W DC Power supplies User Manual* and *HPE 650W AC & 650W DC Power supplies User Manual*.

The LEDs on the power supply are steady green (active) or flashing green (standby) while the power supply system is correctly operating.

### Solution

To resolve the problem:

1. Verify that the power cord is correctly connected.
2. Verify that the power source meets the requirement.
3. Verify that the operating temperature of the switch is in the normal range and the power supply has good ventilation.
4. If the problem persists, contact the Hewlett Packard Enterprise Support.

To replace a power supply, see "[Installing/removing a power supply](#)."

## Fan tray failure

### Symptom

The system status LED on the switch is steady red and the system outputs an alarm message that indicates a fan tray failure.

### Solution

See "[Installing/removing a fan tray](#)" to replace the failed fan tray. If the problem persists, contact the Hewlett Packard Enterprise Support.

Follow these guidelines when you install or remove a fan tray:

- Do not power on the switch when the switch has no fan trays installed.
- You must install two fan trays of the same model for the switch.
- When a fan tray fails during the switch operation and the ambient temperature is not higher than 27°C (80.6°F), replace the fan tray within 24 hours and keep the failed fan tray in position before replacement. If the ambient temperature is higher than 27°C (80.6°F), replace the fan tray immediately.
- Make sure all slots have a module or filler panel installed when the switch is operating.
- When two fan trays fail during the switch operation:
  - For an HPE 5940 32QSFP+ switch, finish replacing the fan trays within 2 minutes on an.
  - For an HPE 5940 48SFP+ 6QSFP+, HPE 5940 48XGT 6QSFP+, HPE 5940 48SFP+ 6QSFP28, or HPE 5940 48XGT 6QSFP28 switch, finish replacing the fan trays within 1 minute.



# Configuration terminal problems

If the configuration environment setup is correct, the configuration terminal displays booting information when the switch is powered on. If the setup is incorrect, the configuration terminal displays nothing or garbled text.

## No display on the configuration terminal

### Symptom

No display is on the configuration terminal when the switch is powered on.

### Solution

To resolve the problem:

1. Verify that the power system is operating correctly.
2. Verify that the console cable has been connected correctly and no fault occurs on the console cable.
3. Verify that the following settings are configured for the terminal:
  - **Baud rate**—9600.
  - **Data bits**—8.
  - **Stop bits**—1.
  - **Parity**—None.
  - **Flow control**—None.
4. If the problem persists, contact Hewlett Packard Enterprise Support.

## Garbled display on the configuration terminal

### Symptom

The configuration terminal displays garbled text.

### Solution

To resolve the problem:

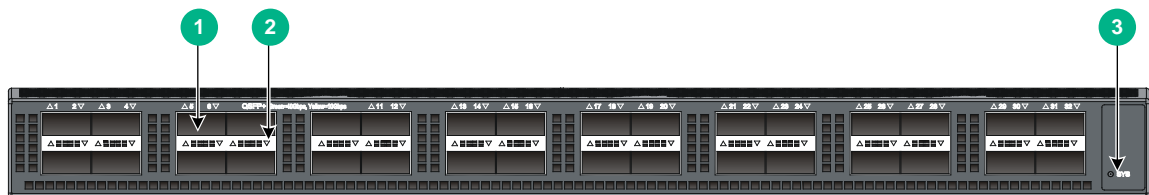
1. Verify that the following settings are configured for the terminal:
  - **Baud rate**—9600.
  - **Data bits**—8.
  - **Stop bits**—1.
  - **Parity**—None.
  - **Flow control**—None.
2. If the problem persists, contact Hewlett Packard Enterprise Support.

# Appendix A Chassis views and technical specifications

## Chassis views

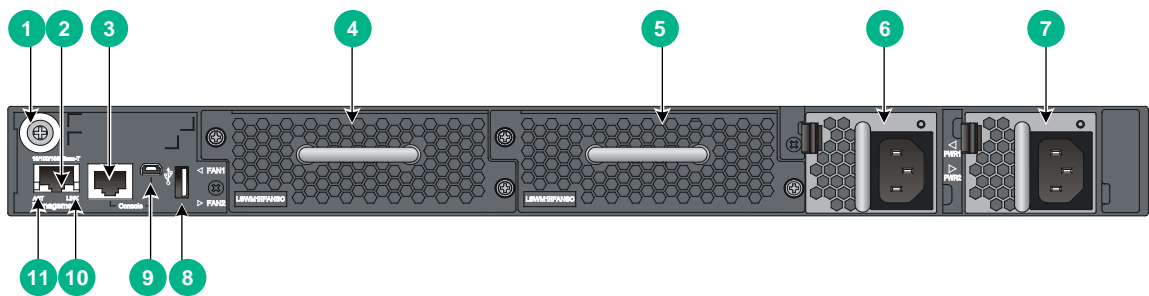
### HPE 5940 32QSFP+

Figure 54 Front panel



- |                             |                    |
|-----------------------------|--------------------|
| (1) QSFP+ port              | (2) QSFP+ port LED |
| (3) System status LED (SYS) |                    |

Figure 55 Rear panel

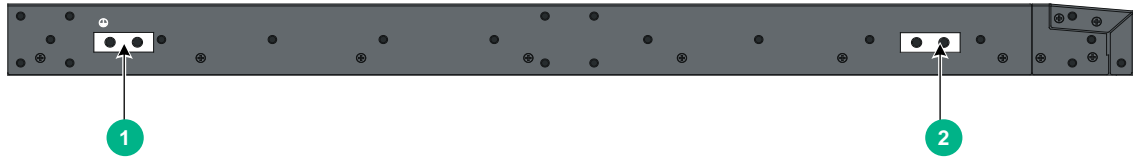


- |   |  |
|---|--|
| (1) Grounding screw (auxiliary grounding point 2) | (2) Management Ethernet port                   |
| (3) Serial console port                           | (4) Fan tray 1                                 |
| (5) Fan tray 2                                    | (6) Power supply 1                             |
| (7) Power supply 2                                | (8) USB port                                   |
| (9) Mini USB console port                         | (10) LINK LED for the management Ethernet port |
| (11) ACT LED for the management Ethernet port     |  |

The HPE 5940 32QSFP+ switch comes with the two power supply slots empty and a power supply filler panel as an accessory. You can install one or two power supplies for the switch as needed. In [Figure 55](#), two 650W AC power supplies are installed in the power supply slots. For more information about installing and removing power supplies, see ["Installing/removing a power supply."](#)

The HPE 5940 32QSFP+ switch comes with the two fan tray slots empty. You must install two fan trays of the same model for the switch. In [Figure 55](#), two LSWM1HFANSC fan trays are installed in the fan tray slots. For more information about installing and removing fan trays, see ["Installing/removing a fan tray."](#)

Figure 56 Left side panel

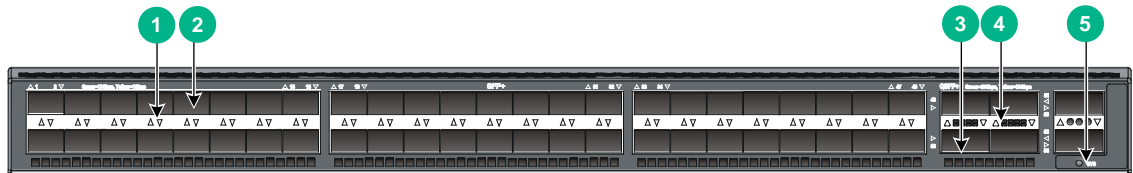


(1) Primary grounding point

(2) Auxiliary grounding point 1

## HPE 5940 48SFP+ 6QSFP+

Figure 57 Front panel



(1) SFP+ port

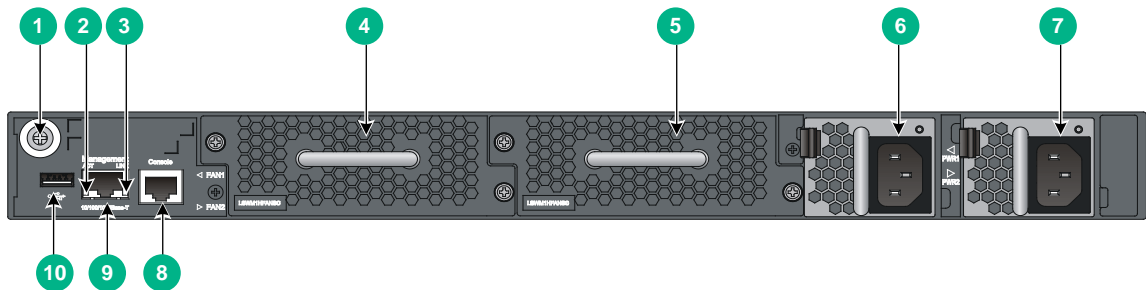
(2) SFP+ port LED

(3) QSFP+ port

(4) QSFP+ port LED

(5) System status LED (SYS)

Figure 58 Rear panel



(1) Grounding screw (auxiliary grounding point 2)

(2) ACT LED for the management Ethernet port

(3) LINK LED for the management Ethernet port

(4) Fan tray 1

(5) Fan tray 2

(6) Power supply 1

(7) Power supply 2

(8) Console port

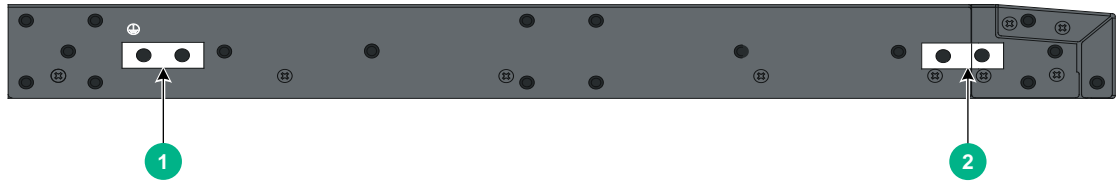
(9) Management Ethernet port

(10) USB port

The HPE 5940 48SFP+ 6QSFP+ switch comes with the two power supply slots empty and a power supply filler panel as an accessory. You can install one or two power supplies for the switch as needed. In [Figure 58](#), two 300W AC power supplies are installed in the power supply slots. For more information about installing and removing power supplies, see ["Installing/removing a power supply."](#)

The HPE 5940 48SFP+ 6QSFP+ switch comes with the two fan tray slots empty. You must install two fan trays of the same model for the switch. In [Figure 58](#), two LSWM1HFANSC fan trays are installed in the fan tray slots. For more information about installing and removing fan trays, see ["Installing/removing a fan tray."](#)

Figure 59 Left side panel



(1) Primary grounding point

(2) Auxiliary grounding point 1

## HPE 5940 48XGT 6QSFP+

Figure 60 Front panel



(1) 1/10GBASE-T autosensing Ethernet port

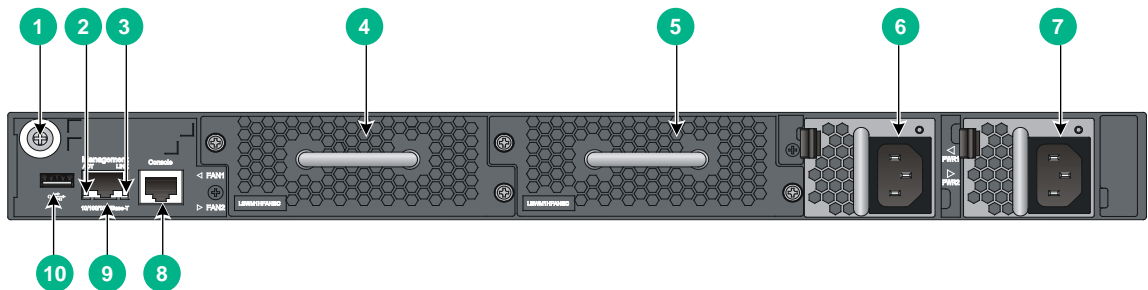
(2) 1/10GBASE-T autosensing Ethernet port LED

(3) System status LED (SYS)

(4) QSFP+ port

(5) QSFP+ port LED

Figure 61 Rear panel



(1) Grounding screw (auxiliary grounding point 2)

(2) ACT LED for the management Ethernet port

(3) LINK LED for the management Ethernet port

(4) Fan tray 1

(5) Fan tray 2

(6) Power supply 1

(7) Power supply 2

(8) Console port

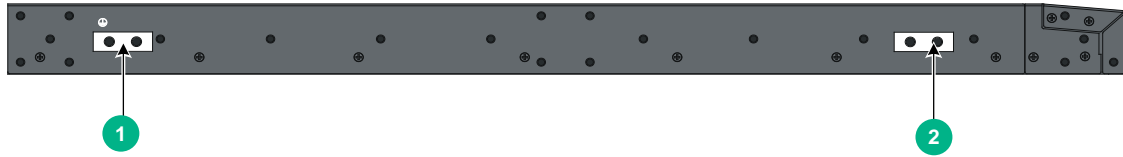
(9) Management Ethernet port

(10) USB port

The HPE 5940 48XGT 6QSFP+ switch comes with the two power supply slots empty and a power supply filler panel as an accessory. You can install one or two power supplies for the switch as needed. In [Figure 61](#), two 650W AC power supplies are installed in the power supply slots. For more information about installing and removing power supplies, see ["Installing/removing a power supply."](#)

The HPE 5940 48XGT 6QSFP+ switch comes with the two fan tray slots empty. You must install two fan trays of the same model for the switch. In [Figure 61](#), two LSWM1HFANSC fan trays are installed in the fan tray slots. For more information about installing and removing fan trays, see ["Installing/removing a fan tray."](#)

Figure 62 Left side panel

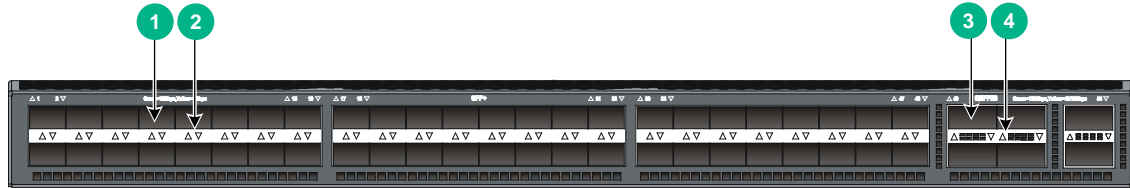


(1) Primary grounding point

(2) Auxiliary grounding point 1

## HPE 5940 48SFP+ 6QSFP28

Figure 63 Front panel



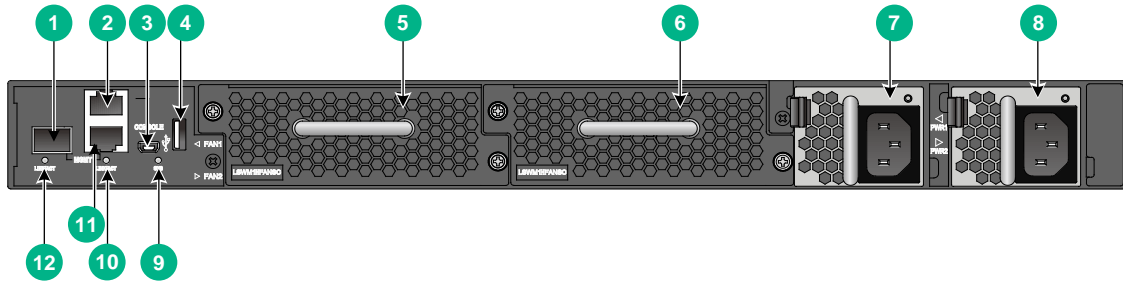
(1) SFP+ port

(2) SFP+ port LED

(3) QSFP28 port

(4) QSFP28 port LED

Figure 64 Rear panel



(1) Fiber management Ethernet port

(2) Console port

(3) Mini USB console port

(4) USB port

(5) Fan tray 1

(6) Fan tray 2

(7) Power supply 1

(8) Power supply 2

(9) System status LED (SYS)

(10) LINK/ACT LED for the copper management Ethernet port

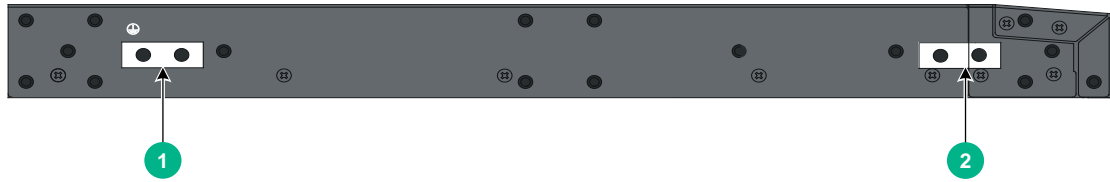
(11) Copper management Ethernet port

(12) LINK/ACT LED for the fiber management Ethernet port

The HPE 5940 48SFP+ 6QSFP28 switch comes with the two power supply slots empty and a power supply filler panel as an accessory. You can install one or two power supplies for the switch as needed. In [Figure 64](#), two 300W AC power supplies are installed in the power supply slots. For more information about installing and removing power supplies, see "[Installing/removing a power supply.](#)"

The HPE 5940 48SFP+ 6QSFP28 switch comes with the two fan tray slots empty. You must install two fan trays of the same model for the switch. In [Figure 64](#), two LSWM1HFANSC fan trays are installed in the fan tray slots. For more information about installing and removing fan trays, see "[Installing/removing a fan tray.](#)"

Figure 65 Left side panel



(1) Primary grounding point

(2) Auxiliary grounding point 1

## HPE 5940 48XGT 6QSFP28

Figure 66 Front panel



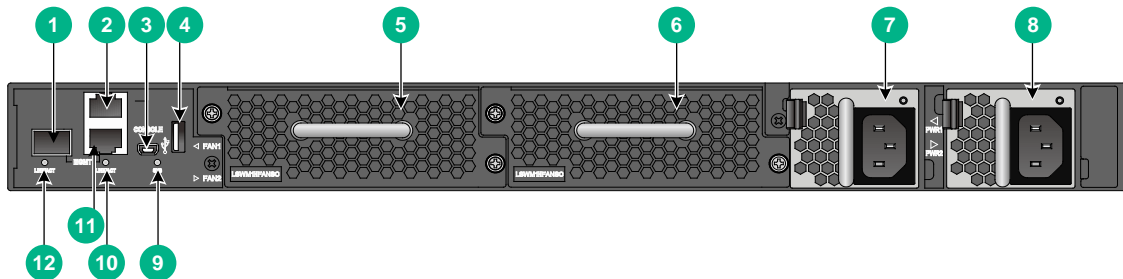
(1) 1/10GBase-T autosensing Ethernet port

(2) 1/10GBase-T autosensing Ethernet port LED

(3) QSFP28 port

(4) QSFP28 port LED

Figure 67 Rear panel



(1) Fiber management Ethernet port

(2) Console port

(3) Mini USB console port

(4) USB port

(5) Fan tray 1

(6) Fan tray slot 2

(7) Power supply 1

(8) Power supply 2

(9) System status LED (SYS)

(10) LINK/ACT LED for the copper management Ethernet port

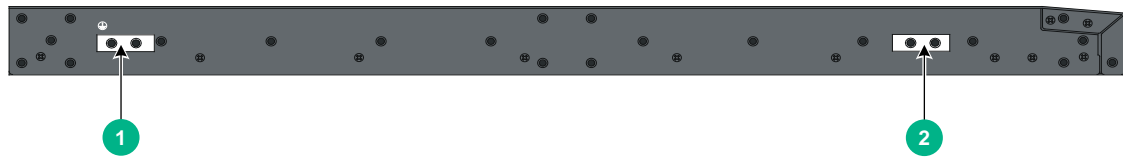
(11) Copper management Ethernet port

(12) LINK/ACT LED for the fiber management Ethernet port

The HPE 5940 48XGT 6QSFP28 switch comes with the two power supply slots empty and a power supply filler panel as an accessory. You can install one or two power supplies for the switch as needed. In [Figure 67](#), two 650W AC power supplies are installed in the power supply slots. For more information about installing and removing power supplies, see "[Installing/removing a power supply.](#)"

The HPE 5940 48XGT 6QSFP28 switch comes with the two fan tray slots empty. You must install two fan trays of the same model for the switch. In [Figure 67](#), two LSWM1HFANSC fan trays are installed in the fan tray slots. For more information about installing and removing fan trays, see "[Installing/removing a fan tray.](#)"

Figure 68 Left side panel

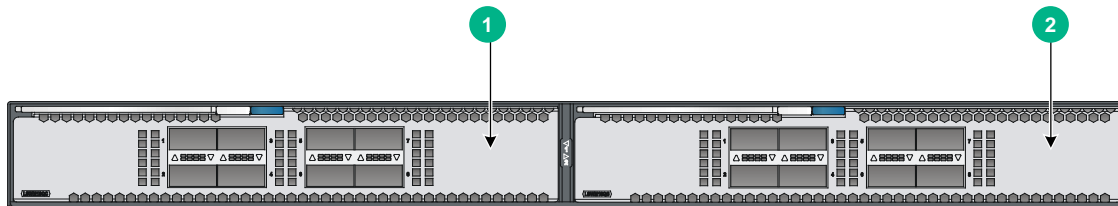


(1) Primary grounding point

(2) Auxiliary grounding point 1

## HPE FlexFabric 5940 2-slot

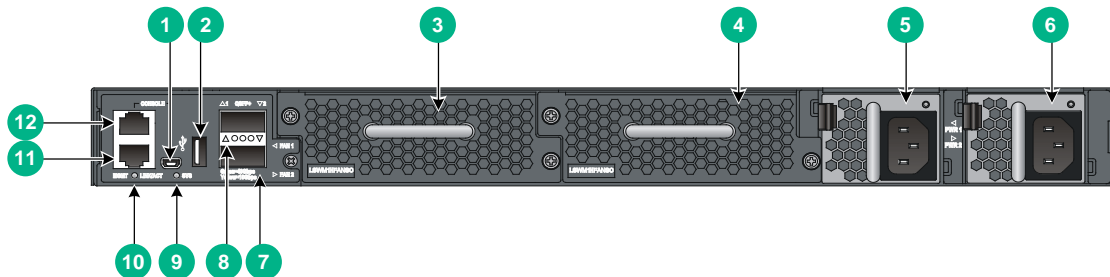
Figure 69 Front panel



(1) Interface module 1

(2) Interface module 2

Figure 70 Rear panel



(1) Mini USB console port

(2) USB port

(3) Fan tray 1

(4) Fan tray 2

(5) Power supply 1

(6) Power supply 2

(7) QSFP+ port

(8) QSFP+ port LED

(9) System status LED (SYS)

(10) LINK/ACT LED for the management Ethernet port

(11) Management Ethernet port

(12) Serial console port

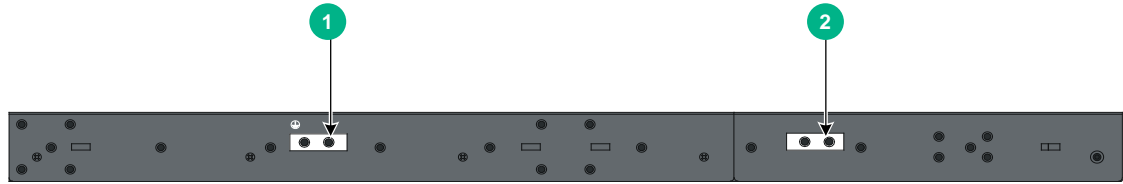
The HPE 5940 2-slot switch comes with interface module slot 1 empty and interface module 2 installed with a filler panel. You can install one or two interface modules for the switch as needed. In [Figure 69](#), two LSWM18QC interface modules are installed in the interface module slots. For more information about installing and removing interface modules, see "[Installing/removing an interface module](#)".

The HPE 5940 2-slot switch comes with the two power supply slots empty and a filler panel for the power supply slot as an accessory. You can install one or two power supplies for the switch as needed. In [Figure 70](#), two 650W AC power supplies are installed in the power supply slots. For more information about installing and removing power supplies, see "[Installing/removing a power supply](#)".

The HPE 5940 2-slot switch comes with the two fan tray slots empty. You must install two fan trays of the same model for the switch. In [Figure 70](#), two LSWM1HFANSC fan trays are installed in the fan

tray slots. For more information about installing and removing fan trays, see "[Installing/removing a fan tray.](#)"

**Figure 71 Left side panel**

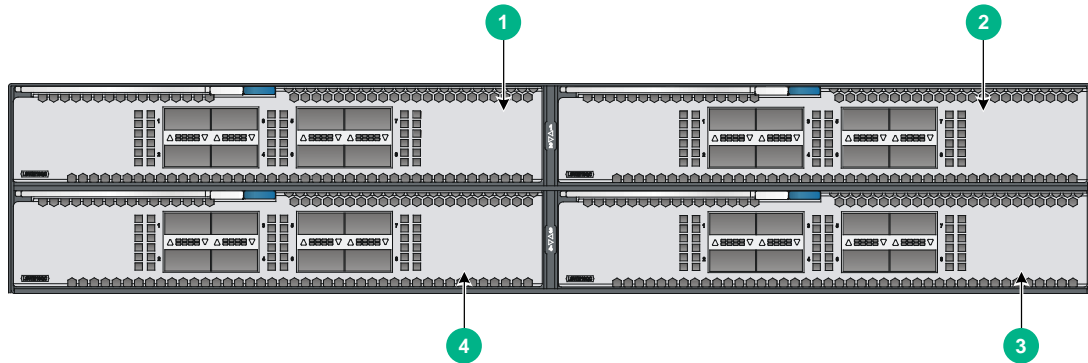


(1) Primary grounding point

(2) Auxiliary grounding point 1

## HPE FlexFabric 5940 4-slot

**Figure 72 Front panel**



(1) Interface module 1

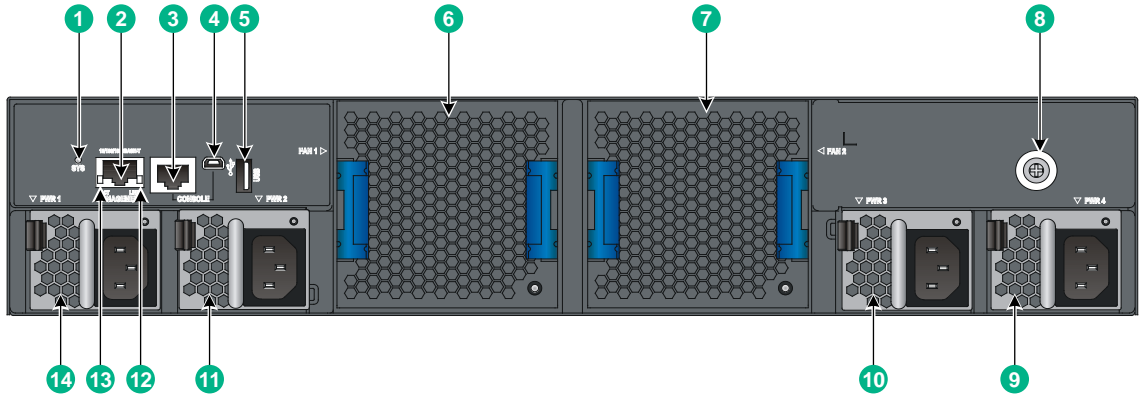
(2) Interface module 2

(3) Interface module 4

(4) Interface module 3



**Figure 73 Rear panel**



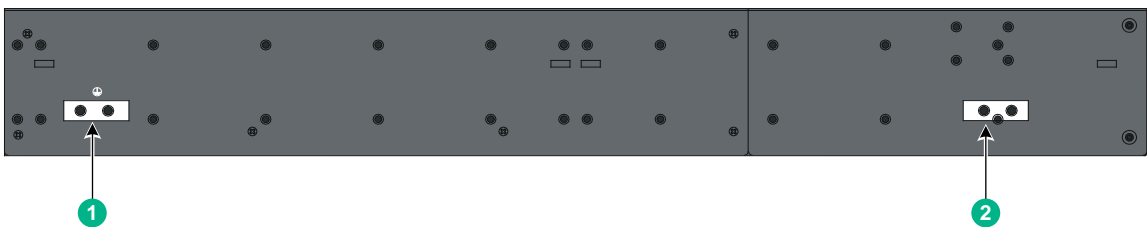
(1) System status LED (SYS)	(2) Management Ethernet port
(3) Serial console port	(4) USB mini console port
(5) USB port	(6) Fan tray 1
(7) Fan tray 2	(8) Grounding screw (auxiliary grounding point 2)
(9) Power supply 4	(10) Power supply 3
(11) Power supply 2	(12) LINK LED for the management Ethernet port
(13) ACT LED for the management Ethernet port	(14) Power supply slot 1

The HPE 5940 4-slot switch comes with a filler panel in each interface module slot except slot 1. You can install one to four interface modules for the switch as needed. In [Figure 72](#), the LSWM18QC interface modules are installed in the interface module slots. For more information about installing and removing interface modules, see "[Installing/removing an interface module.](#)"

The HPE 5940 4-slot switch comes with the four power supply slots empty and two filler panels as accessories. You can install two to four power supplies for the switch as needed. In [Figure 73](#), four 650W AC power supplies are installed in the power supply slots. For more information about installing and removing power supplies, see "[Installing/removing a power supply.](#)"

The HPE 5940 4-slot switch comes with the two fan tray slots empty. You must install two fan trays of the same model for the switch. In [Figure 73](#), two LSWM1BFANSC fan trays are installed in the fan tray slots. For more information about installing and removing fan trays, see "[Installing/removing a fan tray.](#)"

**Figure 74 Left side panel**



(1) Primary grounding point	(2) Auxiliary grounding point 1
-----------------------------	---------------------------------

# Technical specifications

**Table 9 Technical specifications (1)**

Item	HPE 5940 32QSFP+	HPE 5940 48SFP+ 6QSFP+	HPE 5940 48XGT 6QSFP+
Dimensions (H x W x D)	43.6 x 440 x 660 mm (1.72 x 17.32 x 25.98 in)	43.6 x 440 x 460 mm (1.72 x 17.32 x 18.11 in)	43.6 x 440 x 660 mm (1.72 x 17.32 x 25.98 in)
Weight	≤ 13 kg (28.66 lb)	≤ 10 kg (22.05 lb)	≤ 13 kg (28.66 lb)
Console ports	<ul style="list-style-type: none"> <li>1 x mini USB console port</li> <li>1 x serial console port</li> </ul>	1 x serial console port	1 x serial console port
Management Ethernet ports	1	1	1
USB ports	1	1	1
1/10GBASE-T autosensing Ethernet ports	N/A	N/A	48
SFP+ ports	N/A	48	N/A
QSFP+ ports	32	6	6
Fan tray slots	2	2	2
Power supply slots	2	2	2
AC-input voltage	<ul style="list-style-type: none"> <li>Rated voltage: 100 VAC to 240 VAC @ 50 or 60 Hz</li> <li>Max voltage: 90 VAC to 264 VAC @ 47 to 63 Hz</li> </ul>		
DC-input voltage	<ul style="list-style-type: none"> <li>Rated voltage: -40 VDC to -60 VDC</li> <li>Max voltage: -40 VDC to -72 VDC</li> </ul>		
Minimum power consumption	<ul style="list-style-type: none"> <li>Single AC input: 132 W</li> <li>Dual AC inputs: 145 W</li> <li>Single DC input: 128 W</li> <li>Dual DC inputs: 142 W</li> </ul>	<ul style="list-style-type: none"> <li>Single AC input: 75 W</li> <li>Dual AC inputs: 81 W</li> <li>Single DC input: 72 W</li> <li>Dual DC inputs: 80 W</li> </ul>	<ul style="list-style-type: none"> <li>Single AC input: 135 W</li> <li>Dual AC inputs: 150 W</li> <li>Single DC input: 132 W</li> <li>Dual DC inputs: 142 W</li> </ul>
Maximum power consumption	<ul style="list-style-type: none"> <li>Single AC input: 291 W</li> <li>Dual AC inputs: 301 W</li> <li>Single DC input: 291 W</li> <li>Dual DC inputs: 299 W</li> </ul>	<ul style="list-style-type: none"> <li>Single AC input: 145 W</li> <li>Dual AC inputs: 150 W</li> <li>Single DC input: 141 W</li> <li>Dual DC inputs: 145 W</li> </ul>	<ul style="list-style-type: none"> <li>Single AC input: 260 W</li> <li>Dual AC inputs: 270 W</li> <li>Single DC input: 251 W</li> <li>Dual DC inputs: 265 W</li> </ul>
Chassis leakage current compliance	UL60950-1, EN60950-1, IEC60950-1, GB4943		
Melting current of power supply fuse	<ul style="list-style-type: none"> <li>300W AC: 6.3 A @ 250 VAC</li> <li>650W AC: 10 A @ 250 VAC</li> <li>300W DC: 25 A @ 250 VDC</li> <li>650W DC: 30 A @ 250 VDC</li> </ul>		
Operating temperature	0°C to 45°C (32°F to 113°F)	<ul style="list-style-type: none"> <li>0°C to 45°C (32°F to 113°F) when the switch uses two LSWM1HFANSC or LSWM1HFANSCB fan</li> </ul>	0°C to 45°C (32°F to 113°F)

Item	HPE 5940 32QSFP+	HPE 5940 48SFP+ 6QSFP+	HPE 5940 48XGT 6QSFP+
		trays <ul style="list-style-type: none"> <li>0°C to 40°C (32°F to 104°F) when the switch uses two LSWM1FANSC or LSWM1FANSCB fan trays</li> </ul>	
Operating humidity	10% to 90%, noncondensing		
Fire resistance compliance	UL60950-1, EN60950-1, IEC60950-1, GB4943		

**Table 10 Technical specifications (2)**

Item	HPE 5940 48SFP+ 6QSFP28	HPE 5940 48XGT 6QSFP28
Dimensions (H x W x D)	43.6 x 440 x 460 mm (1.72 x 17.32 x 18.11 in)	43.6 x 440 x 660 mm (1.72 x 17.32 x 25.98 in)
Weight	≤ 10 kg (22.05 lb)	≤ 13 kg (28.66 lb)
Console ports	<ul style="list-style-type: none"> <li>1 x mini USB console port</li> <li>1 x serial console port</li> </ul>	<ul style="list-style-type: none"> <li>1 x mini USB console port</li> <li>1 x serial console port</li> </ul>
Management Ethernet ports	<ul style="list-style-type: none"> <li>1 x 10M/100M/1000M Base-T copper port</li> <li>1 x SFP port</li> </ul>	<ul style="list-style-type: none"> <li>1 x 10M/100M/1000M Base-T copper port</li> <li>1 x SFP port</li> </ul>
USB ports	1	1
1/10GBASE-T autosensing Ethernet ports	N/A	48
SFP+ ports	48	N/A
QSFP+ ports	N/A	N/A
QSFP28 ports	6	6
Fan tray slots	2	2
Power supply slots	2	2
AC-input voltage	<ul style="list-style-type: none"> <li>Rated voltage: 100 VAC to 240 VAC @ 50 or 60 Hz</li> <li>Max voltage: 90 VAC to 264 VAC @ 47 to 63 Hz</li> </ul>	
DC-input voltage	<ul style="list-style-type: none"> <li>Rated voltage: -40 VDC to -60 VDC</li> <li>Max voltage: -40 VDC to -72 VDC</li> </ul>	
Minimum power consumption	<ul style="list-style-type: none"> <li>Single AC input: 89 W</li> <li>Dual AC inputs: 95 W</li> <li>Single DC input: 91 W</li> <li>Dual DC inputs: 99 W</li> </ul>	<ul style="list-style-type: none"> <li>Single AC input: 142 W</li> <li>Dual AC inputs: 157 W</li> <li>Single DC input: 135 W</li> <li>Dual DC inputs: 150 W</li> </ul>
Maximum power consumption	<ul style="list-style-type: none"> <li>Single AC input: 186 W</li> <li>Dual AC inputs: 196 W</li> <li>Single DC input: 187 W</li> <li>Dual DC inputs: 192 W</li> </ul>	<ul style="list-style-type: none"> <li>Single AC input: 310 W</li> <li>Dual AC inputs: 320 W</li> <li>Single DC input: 294 W</li> <li>Dual DC inputs: 301 W</li> </ul>
Chassis leakage current	UL60950-1, EN60950-1, IEC60950-1, GB4943	

Item	HPE 5940 48SFP+ 6QSFP28	HPE 5940 48XGT 6QSFP28
compliance		
Melting current of power supply fuse	<ul style="list-style-type: none"> <li>• 300W AC: 6.3 A @ 250 VAC</li> <li>• 650W AC: 10 A @ 250 VAC</li> <li>• 300W DC: 25 A @ 250 VDC</li> <li>• 650W DC: 30 A @ 250 VDC</li> </ul>	
Operating temperature	0°C to 45°C (32°F to 113°F)	0°C to 45°C (32°F to 113°F)
Operating humidity	10% to 90%, noncondensing	
Fire resistance compliance	UL60950-1, EN60950-1, IEC60950-1, GB4943	

**Table 11 Technical specifications (3)**

Item	HPE 5940 2-slot	HPE 5940 4-slot
Dimensions (H x W x D)	44.2 x 440 x 660 mm (1.74 x 17.32 x 25.98 in)	88.1 x 440 x 660 mm (3.47 x 17.32 x 25.98 in)
Weight	≤ 16 kg (35.27 lb)	≤ 27 kg (59.52 lb)
Console port	<ul style="list-style-type: none"> <li>• 1 x mini USB console port</li> <li>• 1 x serial console port</li> </ul>	<ul style="list-style-type: none"> <li>• 1 x mini USB console port</li> <li>• 1 x serial console port</li> </ul>
Management Ethernet port	1	1
USB port	1	1
QSFP+ port	2	N/A
Interface module slot	2	4
Fan tray slot	2	2
Power supply slot	2	4
AC-input voltage	<ul style="list-style-type: none"> <li>• Rated voltage: 100 VAC to 240 VAC @ 50 or 60 Hz</li> <li>• Max voltage: 90 VAC to 264 VAC @ 47 to 63 Hz</li> </ul>	
DC-input voltage	<ul style="list-style-type: none"> <li>• Rated voltage: -40 VDC to -60 VDC</li> <li>• Max voltage: -40 VDC to -72 VDC</li> </ul>	
Minimum power consumption	<ul style="list-style-type: none"> <li>• Single AC input: 95 W</li> <li>• Dual AC inputs: 110 W</li> <li>• Single DC input: 91 W</li> <li>• Dual DC inputs: 105 W</li> </ul>	<ul style="list-style-type: none"> <li>• Dual AC inputs: 135 W</li> <li>• Triple AC inputs: 150 W</li> <li>• Quadruple AC inputs: 165 W</li> <li>• Dual DC inputs: 131 W</li> <li>• Triple DC inputs: 145 W</li> <li>• Quadruple DC inputs: 155 W</li> </ul>
Maximum power consumption	<ul style="list-style-type: none"> <li>• Single AC input: 438 W</li> <li>• Dual AC inputs: 450 W</li> <li>• Single DC input: 443 W</li> <li>• Dual DC inputs: 445 W</li> </ul>	<ul style="list-style-type: none"> <li>• Dual AC inputs: 827 W</li> <li>• Triple AC inputs: 837 W</li> <li>• Quadruple AC inputs: 856 W</li> <li>• Dual DC inputs: 823 W</li> <li>• Triple DC inputs: 825 W</li> <li>• Quadruple DC inputs: 828 W</li> </ul>
Chassis leakage current compliance	<ul style="list-style-type: none"> <li>• UL60950-1, EN60950-1, IEC60950-1, GB4943</li> </ul>	
Melting current of power supply fuse	<ul style="list-style-type: none"> <li>• 10 A @ 250 VAC</li> <li>• 30 A @ 250 VDC</li> </ul>	

Item	HPE 5940 2-slot	HPE 5940 4-slot
Operating temperature	0°C to 45°C (32°F to 113°F)	
Operating humidity	10% to 90%, noncondensing	
Fire resistance compliance	UL60950-1, EN60950-1, IEC60950-1, GB4943	

# Appendix B FRUs and compatibility matrixes

Table 12 Compatibility matrix between the FRUs and HPE FlexFabric 5940 switches

FRUs	HPE 5940 32QSFP+	HPE 5940 48SFP+ 6QSFP+	HPE 5940 48XGT 6QSFP+	HPE 5940 48SFP+ 6QSFP28	HPE 5940 48XGT 6QSFP28	HPE 2-slot	HPE 4-slot
<b>Power supplies</b>							
650W AC	Yes	Yes	Yes	Yes	Yes	Yes	Yes
650W DC	Yes	Yes	Yes	Yes	Yes	Yes	Yes
300W AC	No	Yes	No	Yes	No	No	No
300W DC	No	Yes	No	Yes	No	No	No
<b>Fan trays</b>							
LSWM1FANS C	No	Yes	No	Yes	No	No	No
LSWM1FANS CB	No	Yes	No	Yes	No	No	No
LSWM1HFAN SC	Yes	Yes	Yes	Yes	Yes	Yes	No
LSWM1HFAN SCB	Yes	Yes	Yes	Yes	Yes	Yes	No
LSWM1BFAN SC	No	No	No	No	No	No	Yes
LSWM1BFAN SCB	No	No	No	No	No	No	Yes
<b>Interface modules</b>							
LSWM18QC	No	No	No	No	No	Yes	Yes
LSWM124XG T2Q	No	No	No	No	No	Yes	Yes
LSWM124XG 2Q	No	No	No	No	No	Yes	Yes
LSWM124XG 2QL	No	No	No	No	No	Yes	Yes
LSWM12H2Q	No	No	No	No	No	Yes	Yes

**ⓘ IMPORTANT:**

- The HPE 5940 48SFP+ 6QSFP28, HPE 5940 48XGT 6QSFP28, HPE 5940 48XGT 6QSFP+, HPE 5940 48SFP+ 6QSFP+, HPE 5940 32QSFP+, and HPE 5940 2-slot switches can operate correctly with only one power supply. You can install two power supplies on the switch for 1+1 redundancy.
- The HPE 5940 4-slot switch can operate correctly with two power supplies. You can install four power supplies on the switches for 2+2 redundancy.
- You must install two fan trays of the same model for the switch.
- If an HPE 5940 48SFP+ 6QSFP+ or HPE 5940 48SFP+ 6QSFP28 switch uses 650 W power supplies, you can install two LSWM1HFANSC, LSWM1HFANSCB, LSWM1FANSC, or LSWM1FANSCB fan trays to ensure heat dissipation. If an HPE 5940 48SFP+ 6QSFP+ switch uses 300 W power supplies, you must install two LSWM1FANSC or LSWM1FANSCB fan trays to ensure heat dissipation.

## Power supplies

**⚠ CAUTION:**

When the switch has power supplies in redundancy, you can replace a power supply without powering off the switch. Make sure the power supply to be replaced is powered off before you replace it.

**Table 13 Power supply specifications**

Power supply	Specifications	Remarks
650W AC	<ul style="list-style-type: none"> <li>• Rated input voltage: 100 VAC to 240 VAC @ 50 Hz or 60 Hz</li> <li>• Max input voltage: 90 VAC to 264 VAC @ 47 Hz to 63 Hz</li> <li>• Max output power: 650 W</li> </ul>	For more information about the power supplies, see <i>HPE A58x0AF 650W AC (JC680A) &amp; 650W DC (JC681A) Power Supplies User Guide</i> or <i>HPE FlexFabric Switch 650W 48V Hot Plug NEBS Compliant DC Power Supply (JH336A) User Guide</i> .
650W DC	<ul style="list-style-type: none"> <li>• Rated input voltage: -40 VDC to -60 VDC</li> <li>• Max input voltage: -40 VDC to -72 VDC</li> <li>• Max output power: 650 W</li> </ul>	
300W AC	<ul style="list-style-type: none"> <li>• Rated input voltage: 100 VAC to 240 VAC @ 50 Hz or 60 Hz</li> <li>• Max input voltage: 90 VAC to 264 VAC @ 47 Hz to 63 Hz</li> <li>• Max output power: 315 W</li> </ul>	For more information about the power supplies, see <i>HPE A58x0AF 300W AC (JG900A) &amp; 300W DC (JG901A) Power Supplies User Guide</i> .
300W DC	<ul style="list-style-type: none"> <li>• Rated input voltage: -48 VDC to -60 VDC</li> <li>• Max input voltage: -36 VDC to -72 VDC</li> <li>• Max output power: 315 W</li> </ul>	

# Fan trays

**Table 14 Fan tray specifications**

Item	Specifications
<b>LSWM1HFANSC</b>	
Fans	Two 40 × 40 × 56 mm (1.57 × 1.57 × 2.2 in) fans
Fan speed	21000 R.P.M
Max airflow	70 CFM
Airflow direction	From the power supply side to the port side
Input voltage	12 V
Maximum power consumption	60 W
Documentation reference	<i>HPE LSWM1HFANSC and LSWM1HFANSCB Fan Assemblies Installation</i>
<b>LSWM1HFANSCB</b>	
Fans	Two 40 × 40 × 56 mm (1.57 × 1.57 × 2.2 in) fans
Fan speed	21000 R.P.M
Max airflow	70 CFM
Airflow direction	From the port side to the power supply side
Input voltage	12 V
Maximum power consumption	60 W
Documentation reference	<i>HPE LSWM1HFANSC and LSWM1HFANSCB Fan Assemblies Installation</i>
<b>LSWM1FANSC</b>	
Fans	Two 40 × 40 × 28 mm (1.57 × 1.57 × 1.10 in) fans
Fan speed	18500 R.P.M
Max airflow	45 CFM
Airflow direction	From the power supply side to the port side
Input voltage	12 V
Maximum power consumption	19.5 W
Documentation reference	<i>HPE LSWM1FANSC &amp; LSWM1FANSCB Fan Trays User Guide</i>
<b>LSWM1FANSCB</b>	
Fans	Two 40 × 40 × 28 mm (1.57 × 1.57 × 1.10 in) fans
Fan speed	18500 R.P.M
Max airflow	45 CFM
Airflow direction	From the port side to the power supply side



Item	Specifications
Input voltage	12 V
Maximum power consumption	19.5 W
Documentation reference	<i>HPE LSWM1FANSC &amp; LSWM1FANSCB Fan Trays User Guide</i>
<b>LSWM1BFANSC</b>	
Fans	One 80 × 80 × 76 mm (3.14 × 3.14 × 2.99 in) fan
Fan speed	20000 R.P.M
Max airflow	120 CFM
Airflow direction	From the power supply side to the port side
Input voltage	12 V
Maximum power consumption	57 W
Documentation reference	<i>HPE LSWM1BFANSC &amp; LSWM1BFANSCB Fan Trays User Guide</i>
<b>LSWM1BFANSCB</b>	
Fans	One 80 × 80 × 76 mm (3.14 × 3.14 × 2.99 in) fan
Fan speed	20000 R.P.M
Max airflow	120 CFM
Airflow direction	From the port side to the power supply side
Input voltage	12 V
Maximum power consumption	57 W
Documentation reference	<i>HPE LSWM1BFANSC &amp; LSWM1BFANSCB Fan Trays User Guide</i>

## Interface modules

An HPE 5940 2-slot switch provides two interface module slots. An HPE 5940 4-slot switch provides four interface module slots. Select interface modules for the switch as required.

**Table 15 Interface modules available for the HPE 5940 2-slot/HPE 5940 4-slot switches**

Product code	HPE description	Alias	Interface number and type	Transceiver modules available for the ports
JH183A	HPE 5930 8-port QSFP+ Module	LSWM18QC	8 × QSFP+ port	<ul style="list-style-type: none"> <li>For the transceiver modules and cables available for the SFP+ ports, see "<a href="#">SFP+ port</a>".</li> <li>For the</li> </ul>
JH182A	HPE 5930 24-port 10GBase-T and 2-port QSFP+ with MacSec Module	LSWM124XGT2Q	<ul style="list-style-type: none"> <li>24 × 10-GE copper port</li> <li>2 × QSFP+ port</li> </ul>	
JH181A	HPE 5930 24-port	LSWM124XG2Q	<ul style="list-style-type: none"> <li>24 × SFP+ port</li> </ul>	

Product code	HPE description	Alias	Interface number and type	Transceiver modules available for the ports
	SFP+ and 2-port QSFP+ with MacSec Module		<ul style="list-style-type: none"> <li>2 x QSFP+ port</li> </ul>	transceiver modules and cables available for the QSFP+ ports, see <a href="#">"QSFP+ port"</a> . <ul style="list-style-type: none"> <li>For the transceiver modules and cables available for the QSFP28 ports, see <a href="#">"QSFP28 port"</a>.</li> </ul>
JH180A	HPE 5930 24-port SFP+ and 2-port QSFP+ Module	LSWM124XG2QL		
JH184A	HPE 5930 24-port Converged Port and 2-port QSFP+ Module	LSWM124XG2QFC		
JH409A	HPE 5940 2-port QSFP+ and 2-port QSFP28 Module	LSWM12H2Q	<ul style="list-style-type: none"> <li>2 x QSFP+ port</li> <li>2 x QSFP28 port</li> </ul>	

**!** **IMPORTANT:**

- On an HPE 5940 4-slot switch (JH398A), the 40-GE QSFP+ ports on the LSWM124XGT2Q (JH182A), LSWM124XG2Q (JH181A), LSWM124XG2QL (JH180A), and LSWM124XG2QFC (JH184A) interface modules cannot be split into four 10-GE SFP+ ports. The two highest-numbered 40-GE QSFP+ ports (ports 7 and 8) on an LSWM18QC (JH183A) interface module cannot be split into four 10-GE SFP+ ports.
- The LSWM12H2Q interface module (JH409A) can only be installed in the two interface module slots on an HPE 5940 2-slot switch (JH397A) and in interface module slots 1 and 2 on an HPE 5940 4-slot switch (JH398A). On an HPE 5940 2-slot switch, an interface module slot supports hot swapping of LSWM12H2Q interface modules only if it starts up with an LSWM12H2Q interface module installed. On an HPE 5940 4-slot switch, both interface module slots 1 and 2 support hot swapping of LSWM12H2Q interface modules if one of them starts up with an LSWM12H2Q interface module installed. If both the slots start up empty, neither of them supports hot swapping of LSWM12H2Q interface modules.
- You can install the LSWM12H2Q and non-LSWM12H2Q interface modules on the same HPE 5940 2-slot switch. If an interface module slot starts up with an LSWM12H2Q interface module installed, you can hot-swap only LSWM12H2Q interface modules in the slot. If an interface module slot starts up empty or with a non-LSWM12H2Q interface module installed, you can hot-swap only non-LSWM12H2Q interface modules in the slot. If you change the interface module type in a slot, you need to reboot the switch for the interface module to operate correctly.
- You must install the same type of interface modules either LSWM12H2Q or non-LSWM12H2Q in interface module slots 1 and slot 2 on the same HPE 5940 4-slot switch. If one or both of the interface module slots start up with an LSWM12H2Q interface card installed, you can hot-swap only LSWM12H2Q interface modules in the two slots. If both interface module slots start up empty, or one or both of the interface module slots start up with a non-LSWM12H2Q interface module installed, you can hot-swap only non-LSWM12H2Q interface modules in the two slots.

For more information about the interface modules, see the user manuals for the interface modules.

# Appendix C Ports and LEDs

## Ports

### Console port

The HPE 5940 48SFP+ 6QSFP+ and HPE 5940 48XGT 6QSFP+ switches each have one console port.

**Table 16 Console port specifications**

Item	Specification
Connector type	RJ-45
Compliant standard	EIA/TIA-232
Transmission baud rate	9600 bps (default) to 115200 bps
Services	<ul style="list-style-type: none"><li>Provides connection to an ASCII terminal.</li><li>Provides connection to the serial port of a local or remote (through a pair of modems) PC running terminal emulation program.</li></ul>

The HPE 5940 32QSFP+, HPE 5940 48XGT 6QSFP28, and HPE 5940 48SFP+ 6QSFP28 switches have two console ports: serial console port and Mini USB console port.

**Table 17 Console port specifications**

Item	Console port	Mini USB console port
Connector type	RJ-45	USB mini-Type B
Compliant standard	EIA/TIA-232	USB 2.0
Transmission baud rate	9600 bps (default) to 115200 bps	
Services	<ul style="list-style-type: none"><li>Provides connection to an ASCII terminal.</li><li>Provides connection to the serial port of a local or remote (through a pair of modems) PC running terminal emulation program.</li></ul>	<ul style="list-style-type: none"><li>Provides connection to an ASCII terminal.</li><li>Provides connection to the USB port of a local PC running terminal emulation program.</li></ul>

### Management Ethernet port

The HPE 5940 32QSFP+, HPE 5940 48XGT 6QSFP+, and HPE 5940 48SFP+ 6QSFP+ switches each provide a copper management Ethernet port. The HPE 5940 48SFP+ 6QSFP28 and HPE 5940 48XGT 6QSFP28 switches each provide a copper and a fiber management Ethernet port. You can connect this port to a PC or management station for loading and debugging software or remote management.

**Table 18 Copper management Ethernet port specifications**

Item	Specification
Connector type	RJ-45
Connector quantity	1
Port transmission rate	10/100/1000 Mbps, half/full duplex
Transmission medium and max transmission distance	100 m (328.08 ft) over category-5 twisted pair cable
Functions and services	Switch software and Boot ROM upgrade, network management

**Table 19 Fiber management Ethernet port specifications**

Item	Specification
Connector type	LC
Connector quantity	1
Port transmission rate	100/1000 Mbps, full duplex
Transmission medium and max transmission distance	See <a href="#">Table 20</a> and <a href="#">Table 21</a> .
Functions and services	Software upgrade and network management

**Table 20 FE SFP transceiver modules**

Product code	HPE description	Central wavelength (nm)	Connector	Fiber type and diameter (µm)	Max transmission distance
JD102B	HPE X115 100M SFP LC FX Transceiver	1310	LC	Multi-mode, 50/125	2 km (1.24 miles)
				Multi-mode, 62.5/125	
JD120B	HPE X110 100M SFP LC LX Transceiver	1310	LC	Single-mode, 9/125	15 km (9.32 miles)

## USB port

The switch has one OHC-compliant USB2.0 port that can upload and download data at a rate up to 480 Mbps. You can use this USB port to access the file system on the Flash of the switch, for example, to upload or download application and configuration files.

---

### NOTE:

USB devices from different manufacturers vary in compatibilities and drivers. Hewlett Packard Enterprise does not guarantee the correct operation of all USB devices on the switch. If a USB device fails to operate on the switch, replace it with one from another manufacturer.

---

## SFP+ port

The HPE 5940 48SFP+ 6QSFP+ switch provides SFP+ ports. The LSWM124XG2Q (JH181A), LSWM124XG2QL (JH180A), and LSWM124XG2QFC (JH184A) interface modules available for the HPE 5940 2-slot and HPE 5940 4-slot switches also provide SFP+ ports. You can install Gigabit SFP transceiver modules in [Table 21](#), 10-Gigabit SFP+ transceiver modules in [Table 22](#), and 10-Gigabit SFP+ cables in [Table 23](#) in the SFP+ ports as needed.

**Table 21 Gigabit SFP transceiver modules available for the SFP+ ports**

Product code	HPE description	Central wavelength (nm)	Connector	Cable/Fiber type and diameter (μm)	Modal bandwidth (MHz × km)	Max transmission distance
JD089B	HPE X120 1G SFP RJ45 T Transceiver	N/A	RJ-45	Category-5 twisted pair	N/A	100 m (328.08 ft)
JD118B	HPE X120 1G SFP LC SX Transceiver	850	LC	Multi-mode, 50/125	500	550 m (1804.46 ft)
					400	500 m (1640.42 ft)
				Multi-mode, 62.5/125	200	275 m (902.23 ft)
					160	220 m (721.78 ft)
JD119B	HPE X120 1G SFP LC LX Transceiver	1310	LC	Single-mode, 9/125	N/A	10 km (6.21 miles)
				Multi-mode, 50/125	500 or 400	550 m (1804.46 ft)
				Multi-mode, 62.5/125	500	550 m (1804.46 ft)
JD061A	HPE X125 1G SFP LC LH40 1310nm Transceiver	1310	LC	Single-mode, 9/125	N/A	40 km (24.86 miles)
JD062A	HPE X120 1G SFP LC LH40 1550nm Transceiver	1550	LC	Single-mode, 9/125	N/A	40 km (24.86 miles)
JD063B	HPE X125 1G SFP LC LH80 Transceiver	1550	LC	Single-mode, 9/125	N/A	80 km (49.71 miles)

**Table 22 10-Gigabit SFP+ transceiver modules available for the SFP+ ports**

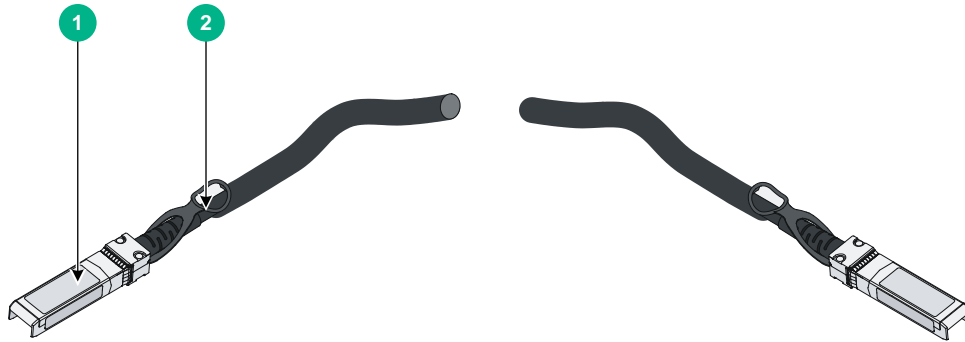
Product code	HPE description	Central wavelength (nm)	Connector	Fiber type and diameter (μm)	Modal bandwidth (MHz × km)	Max transmission distance
JD092B	HPE X130 10G SFP+ LC SR	850	LC	Multi-mode, 50/125	2000	300 m (984.25 ft)
					500	82 m

Product code	HPE description	Central wavelength (nm)	Connector	Fiber type and diameter (µm)	Modal bandwidth (MHz × km)	Max transmission distance
	Transceiver					(269.03 ft)
					400	66 m (216.54 ft)
				Multi-mode, 62.5/125	200	33 m (108.27 ft)
					160	26 m (85.30 ft)
JD094B	HPE X130 10G SFP+ LC LR Transceiver	1310	LC	Single-mode, 9/125	N/A	10 km (6.21 miles)
JG879A	HPE X190 8G/4G/2G SFP+ LC Short Wave Transceiver	850	LC	Multi-mode, 62.5/125	200	150 m (492.13 ft)
				Multi-mode, 50/125	500	380 m (1246.72 ft)
					2000	500 m (1640.42 ft)
JG880A	HPE X190 8G/4G/2G SFP+ LC Long Wave Transceiver	1310	LC	Single-mode, 9/125	N/A	10 km (6.21 miles)

**Table 23 SFP+ cables available for the SFP+ ports**

Product code	HPE description	Max transmission distance	Data rate
JD095C	HPE X240 10G SFP+ SFP+ 0.65m DA Cable	0.65 m (2.13 ft)	10.31 Gbps
JD096C	HPE X240 10G SFP+ SFP+ 1.2m DA Cable	1.2 m (3.94 ft)	10.31 Gbps
JD097C	HPE X240 10G SFP+ SFP+ 3m DA Cable	3 m (9.84 ft)	10.31 Gbps
JG081C	HPE X240 10G SFP+ SFP+ 5m DA Cable	5 m (16.40 ft)	10.31 Gbps

**Figure 75 SFP+ cable**



(1) Connector

(2) Pull latch

**NOTE:**

As a best practice, use HPE SFP transceiver modules, SFP+ transceiver modules, or SFP+ cables for the SFP+ ports on the switch. The HPE SFP transceiver modules, SFP+ transceiver modules, and SFP+ cables for the SFP+ ports are subject to change over time. For the most up-to-date list of SFP transceiver modules, SFP+ transceiver modules, and SFP+ cables available for the SFP+ ports, contact Hewlett Packard Enterprise Support or marketing staff.

For more information about HPE SFP transceiver modules, SFP+ transceiver modules, and SFP+ cables, see *HPE Transceiver Modules User Guide*.

## QSFP+ port

The HPE 5940 32QSFP+, HPE 5940 48XGT 6QSFP+, and HPE 5940 48SFP+ 6QSFP+ switches provide fixed QSFP+ ports. The interface modules available for the HPE 5940 2-slot and HPE 5940 4-slot switches also provide QSFP+ ports. You can install QSFP+ transceiver modules in [Table 24](#), QSFP+ cables in [Table 25](#), and QSFP+ to 4 x SFP+ cables in [Table 26](#) in the QSFP+ ports as needed.

**Table 24 40G QSFP+ transceiver modules available for the QSFP+ ports**

Product code	HPE description	Central wavelength (nm)	Connector	Fiber type and diameter (µm)	Modal bandwidth (MHz x km)	Max transmission distance
JG325B	HPE X140 40G QSFP+ MPO SR4 Transceiver	850	MPO	Multi-mode, 50/125	2000	100 m (328.08 ft)
					4700	150 m (492.12 ft)
JG709A	HPE X140 40G QSFP+ MPO MM 850nm CSR4 300m Transceiver	850	MPO	Multi-mode, 50/125	2000	300 m (984.25 ft)
					4700	400 m (1312.33 ft)
JG661A	HPE X140 40G QSFP+ LC LR4 SM 10km 1310nm	Four lanes: <ul style="list-style-type: none"> <li>1271.</li> <li>1291.</li> </ul>	LC	Single-mode, 9/125	N/A	10 km (6.21 miles)

Product code	HPE description	Central wavelength (nm)	Connector	Fiber type and diameter (μm)	Modal bandwidth (MHz × km)	Max transmission distance
	Transceiver	<ul style="list-style-type: none"> <li>• 1311.</li> <li>• 1331.</li> </ul>				

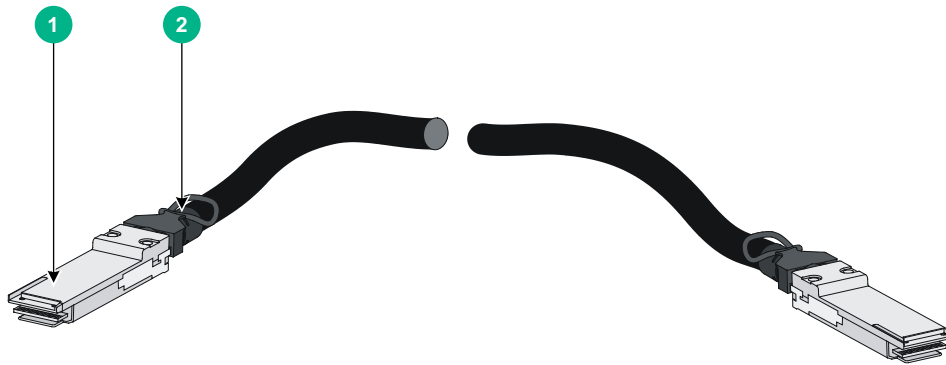
**Table 25 40G QSFP+ cables available for the QSFP+ ports**

Product Code	HPE description	Cable length
JG326A	HPE X240 40G QSFP+ QSFP+ 1m Direct Attach Copper Cable	1 m (3.28 ft)
JG327A	HPE X240 40G QSFP+ QSFP+ 3m Direct Attach Copper Cable	3 m (9.84 ft)
JG328A	HPE X240 40G QSFP+ QSFP+ 5m Direct Attach Copper Cable	5 m (16.40 ft)

**Table 26 40G QSFP+ to SFP+ cables available for the QSFP+ ports**

Product Code	HPE description	Cable length
JG329A	HPE X240 40G QSFP+ to 4x10G SFP+ 1m Direct Attach Copper Splitter Cable	1 m (3.28 ft)
JG330A	HPE X240 40G QSFP+ to 4x10G SFP+ 3m Direct Attach Copper Splitter Cable	3 m (9.84 ft)
JG331A	HPE X240 40G QSFP+ to 4x10G SFP+ 5m Direct Attach Copper Splitter Cable	5 m (16.40 ft)

**Figure 76 QSFP+ cable**

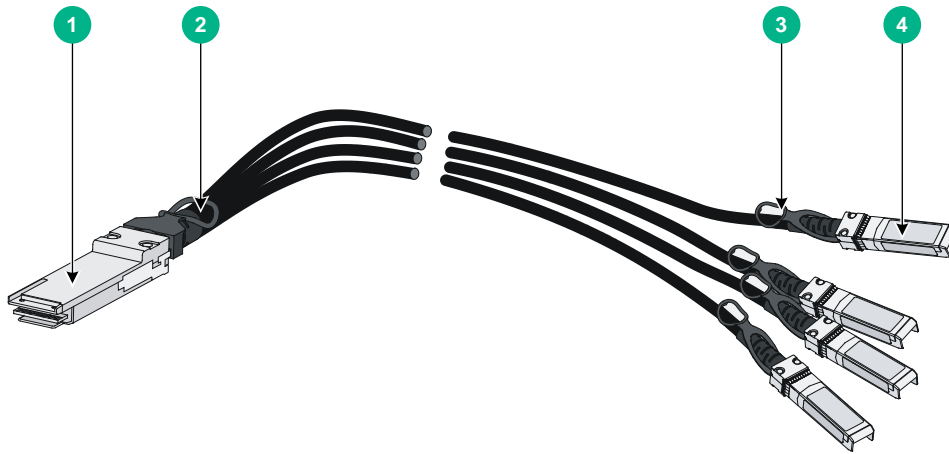


(1) Connector

(2) Pull latch



Figure 77 QSFP+ to 4 x SFP+ cable



(1) QSFP+ module	(2) QSFP+ side pull latch
(3) SFP+ side pull latch	(4) SFP+ module

**!** **IMPORTANT:**

- 40-GE QSFP+ ports FortyGigE 1/0/1 through FortyGigE 1/0/4 and FortyGigE 1/0/29 through FortyGigE 1/0/32 on an HPE 5940 32QSFP+ switch (JH396A) cannot be split into 10-GE SFP+ ports.
- On an HPE 5940 4-slot switch (JH398A), the 40-GE QSFP+ ports on the LSWM124XGT2Q (JH182A), LSWM124XG2Q (JH181A), LSWM124XG2QL (JH180A), and LSWM124XG2QFC (JH184A) interface modules cannot be split into four 10-GE SFP+ ports. The two highest-numbered 40-GE QSFP+ ports (ports 7 and 8) on an LSWM18QC (JH183A) interface module cannot be split into four 10-GE SFP+ ports.

**NOTE:**

- As a best practice, use HPE QSFP+ transceiver modules, QSFP+ cables, or QSFP+ to 4 x SFP+ cables for the QSFP+ ports on the switch. The HPE QSFP+ transceiver modules, QSFP+ cables, and QSFP+ to 4 x SFP+ cables available for the QSFP+ ports are subject to change over time. For the most recent list of QSFP+ transceiver modules, QSFP+ cables, and QSFP+ to 4 x SFP+ cables available for the QSFP+ ports, contact Hewlett Packard Enterprise Support or marketing staff.
- You can use a QSFP-40G-SR4-MM850 or QSFP-40G-CSR4-MM850 transceiver module to connect a QSFP+ port to four SFP+ ports. The QSFP+ transceiver module and SFP+ transceiver modules to be connected must be the same in specifications, including central wavelength and fiber type.
- 40-GE QSFP+ ports FortyGigE 1/0/1 through FortyGigE 1/0/4 and FortyGigE 1/0/29 through FortyGigE 1/0/32 on an HPE FlexFabric 5940 32QSFP+ Switch (JH396A) cannot be split into 10-GE SFP+ ports.

For more information about HPE QSFP+ transceiver modules, QSFP+ cables, and QSFP+ to 4 x SFP+ cables, see *HPE Transceiver Modules User Guide*.

## QSFP28 port

The HPE 5940 48SFP+ 6QSFP28 and HPE 5940 48XGT 6QSFP28 switches provide QSFP28 ports. The LSWM12H2Q interface module (JH409A) available for the HPE 5940 2-slot and HPE 5940 4-slot switches also provides QSFP28 ports. You can install QSFP+ modules or cables in [Table 24](#) and [Table 25](#), and QSFP28 modules or cables in [Table 27](#) and [Table 28](#) in the QSFP28 ports as needed.

**Table 27 QSFP28 transceiver modules available for the QSFP28 ports**

Product code	HPE description	Central wavelength (nm)	Connector	Fiber type and diameter (µm)	Modal bandwidth (MHz × km)	Max transmission distance
JL274A	HPE X150 100G QSFP28 MPO SR4 100m MM Transceiver	850	MPO	Multi-mode, 50/125	2000	70 m (229.66 ft)
					4700	100 m (328.08 ft)
JL275A	HPE X150 100G QSFP28 LC LR4 10km SM Transceiver	Four lanes: <ul style="list-style-type: none"> <li>• 1295</li> <li>• 1300</li> <li>• 1304</li> <li>• 1309</li> </ul>	LC	Single-mode, 9/125	N/A	10 km (6.21 miles)

**Table 28 QSFP28 cables available for the QSFP28 ports**

Product Code	HPE description	Cable length
JL271A	HPE X240 100G QSFP28 to QSFP28 1m Direct Attach Copper Cable	1 m (3.28 ft)
JL272A	HPE X240 100G QSFP28 to QSFP28 3m Direct Attach Copper Cable	3 m (9.84 ft)
JL273A	HPE X240 100G QSFP28 to QSFP28 5m Direct Attach Copper Cable	5 m (16.40 ft)



**IMPORTANT:**

A QSFP28 port cannot be split into four 10GE ports.

**NOTE:**

As a best practice, use HPE QSFP+/QSFP28 transceiver modules and cables for the QSFP28 ports. The available HPE QSFP+/QSFP28 transceiver modules and cables are subject to change over time. For the most recent list of available HPE QSFP+/QSFP28 transceiver modules and cables, contact Hewlett Packard Enterprise Support or marketing staff.

## 1/10GBASE-T autosensing Ethernet port

The HPE 5940 48XGT 6QSFP+ switch provides 1/10GBASE-T autosensing Ethernet ports.

**Table 29 1/10GBASE-T autosensing Ethernet port specifications**

Item	Specification
Connector type	RJ-45
Port transmission rate	1/10 Gbps, full duplex, MDI/MDI-X autosensing
Transmission medium and max transmission distance	<ul style="list-style-type: none"> <li>• 55 m (180.45 ft) over category-6 unshielded twisted pair cable</li> <li>• 100 m (328.08 ft) over category-6 shielded twisted pair cable</li> <li>• 100 m (328.08 ft) over category-6A or above twisted pair cable</li> </ul>
Compatible standards	<ul style="list-style-type: none"> <li>• IEEE 802.3ab</li> <li>• IEEE 802.3an</li> </ul>

To avoid interference between cables, layer cables as follows:

- Use category-6A or above cables and connectors.
- Do not bundle cables in their first 20 m (65.62 ft).
- Separate power cords and twisted pair cables at and around the distribution frame.
- For ports adjacent to one another on the device, the peer ports on the distribution frame are preferably not adjacent, for example:
  - If the device connects to one distribution frame, connect port 1 on the device to port 1 on the distribution frame, port 2 on the device to port 3 on the distribution frame, and port 3 on the device to port 5 on the distribution frame.
  - If the device connects to two distribution frames, connect port 1 on the device to port 1 on distribution frame 1, port 2 on the device to port 1 on distribution frame 2, and port 3 on the device to port 2 on distribution frame 1.

## LEDs

### System status LED

The system status LED shows the operating status of the switch.

**Table 30 System status LED description**

LED mark	Status	Description
SYS	Steady green	The switch is operating correctly.
	Flashing green	The switch is performing power-on self test (POST).
	Steady red	The system has failed to pass POST or has problems such as fan failure.
	Flashing red	Some ports have failed to pass POST.
	Off	The switch is powered off or has failed to start up.

### SFP+ port LED

Each SFP+ port has a status LED to show its operating status and activities.

**Table 31 SFP+ port LED description**

LED status	Description
Steady green	A transceiver module or cable has been correctly installed. The port has a link and is operating at 10 Gbps.
Flashing green	The port is sending or receiving data at 10 Gbps.
Steady yellow	A transceiver module or cable has been correctly installed. The port has a link and is operating at 1 Gbps.
Flashing yellow	The port is sending or receiving data at 1 Gbps.
Off	No transceiver module or cable has been installed or no link is present on the port.

### QSFP+ port LED

Each QSFP+ port has a status LED to show its operating status and activities.

**Table 32 QSFP+ port LED description**

LED status	Description
Steady green	A transceiver module or cable has been correctly installed. The port has a link and is operating at 40 Gbps.
Flashing green	The port is sending or receiving data at 40 Gbps.
Steady yellow	A transceiver module or cable has been correctly installed. The port has a link and is operating at 10 Gbps.
Flashing yellow	The port is sending or receiving data at 10 Gbps.
Off	No transceiver module or cable has been installed or no link is present on the port.

## QSFP28 port LED

Each QSFP28 port has a status LED to show its operating status and activities.

**Table 33 QSFP28 port LED description**

LED status	Description
Steady green	A transceiver module or cable has been correctly installed. The port has a link and is operating at 100 Gbps.
Flashing green	The port is sending or receiving data at 100 Gbps.
Steady yellow	A transceiver module or cable has been correctly installed. The port has a link and is operating at 10/40 Gbps.
Flashing yellow (3 Hz)	The port is sending or receiving data at 10/40 Gbps.
Off	No transceiver module or cable has been installed or no link is present on the port.

## Management Ethernet port LEDs

The HPE 5940 32QSFP+, HPE 5940 48XGT 6QSFP+, and HPE 5940 48SFP+ 6QSFP+ switches each provide one LINK LED and one ACT LED for the management Ethernet port.

**Table 34 Description for the management Ethernet port LEDs on the HPE 5940 32QSFP+, HPE 5940 48XGT 6QSFP+, and HPE 5940 48SFP+ 6QSFP+ switches**

LED mark	Status	Description
LINK	Off	The management Ethernet port is not connected.
	Steady green	The management Ethernet port is operating at 10/100/1000 Mbps.
ACT	Off	The management Ethernet port is not receiving or sending data.
	Flashing yellow	The management Ethernet port is sending or receiving data.

The HPE 5940 48SFP+ 6QSFP28 and HPE 5940 48XGT 6QSFP28 switches provide a LINK/ACT LED for each management Ethernet port.

**Table 35 Description for the copper management Ethernet port LED on the HPE 5940 48SFP+6QSFP28 and HPE 5940 48XGT 6QSFP28 switches**

LED mark	Status	Description
LINK/ACT	Steady green	The copper management Ethernet port is operating at 10/100/1000 Mbps and a link is present.
	Flashing green	The copper management Ethernet port is receiving or sending data.
	Off	The copper management Ethernet port is not connected.

**Table 36 Description for the fiber management Ethernet port LED on the HPE 5940 48SFP+6QSFP28 and HPE 5940 48XGT 6QSFP28 switches**

LED mark	Status	Description
LINK/ACT	Off	The fiber management Ethernet port is not connected.
	Steady green	The fiber management Ethernet port is operating at 1000 Mbps.
	Flashing green	The fiber management Ethernet port is receiving or sending data at 1000 Mbps.
	Steady yellow	The fiber management Ethernet port is operating at 100 Mbps.
	Flashing yellow	The fiber management Ethernet port is receiving or sending data at 100 Mbps.

## 1/10GBASE-T autosensing Ethernet port LEDs

**Table 37 1/10GBASE-T autosensing Ethernet port LED description**

Status	Description
Steady green	The port has a link and is operating at 10 Gbps.
Flashing green	The port is sending or receiving data at 10 Gbps.
Steady yellow	The port has a link and is operating at 1 Gbps.
Flashing yellow	The port is sending or receiving data at 1 Gbps.
Off	No link is present on the port.

## Fan tray alarm LEDs

The LSWM1BFANSC and LSWM1BFANSCB fan trays provide an Alarm LED.

**Table 38 LSWM1BFANSC and LSWM1BFANSCB fan tray alarm LED description**

Status	Description
On	The fan tray is faulty.
Off	The fan tray is operating correctly.

# Appendix D Cooling system

**△ CAUTION:**

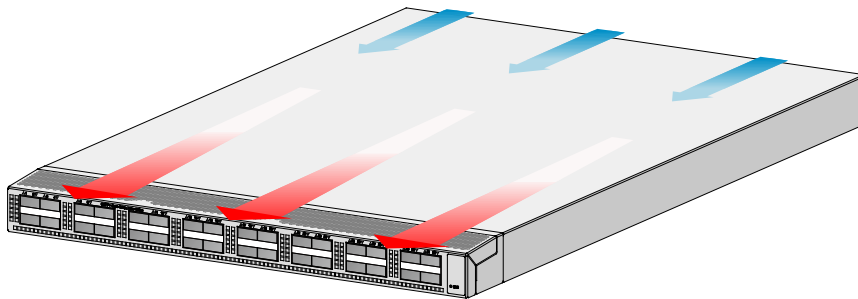
To guarantee heat dissipation, you must install two fan trays of the same model for the switch.

To dissipate heat timely and ensure system stability, the switch uses the front-rear air aisle cooling system. Consider the site ventilation design when you plan the installation site for the switch.

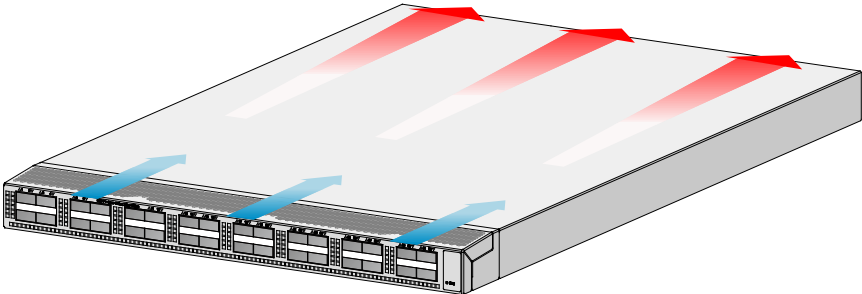
**Table 39 Cooling system for the switch**

Switch model	Available fan trays	Airflow direction
<ul style="list-style-type: none"> <li>HPE 5940 32QSFP+</li> <li>HPE 5940 48SFP+ 6QSFP+</li> <li>HPE 5940 48XGT 6QSFP+</li> <li>HPE 5940 2-slot</li> </ul>	LSWM1HFANSC	From the power supply side to the port side
	LSWM1HFANSCB	From the port side to the power supply side
<ul style="list-style-type: none"> <li>HPE 5940 48SFP+ 6QSFP28</li> <li>HPE 5940 48XGT 6QSFP28</li> </ul>	LSWM1FANSC or LSWM1HFANSC	From the power supply side to the port side
	LSWM1FANSCB or LSWM1HFANSCB	From the port side to the power supply side
HPE 5940 4-slot	LSWM1BFANSC	From the power supply side to the port side
	LSWM1BFANSCB	From the port side to the power supply side

**Figure 78 Airflow from the power supply side to the port side through the HPE 5940 32QSFP+ chassis (with LSWM1HFANSC fan trays)**



**Figure 79 Airflow from the port side to the power supply side through the HPE 5940 32QSFP+ chassis (with LSWM1HFANSCB fan trays)**



# Document conventions and icons

## Conventions

This section describes the conventions used in the documentation.

### Port numbering in examples

The port numbers in this document are for illustration only and might be unavailable on your device.




### Command conventions

Convention	Description
<b>Boldface</b>	<b>Bold</b> text represents commands and keywords that you enter literally as shown.
<i>Italic</i>	<i>Italic</i> text represents arguments that you replace with actual values.
[ ]	Square brackets enclose syntax choices (keywords or arguments) that are optional.
{ x   y   ... }	Braces enclose a set of required syntax choices separated by vertical bars, from which you select one.
[ x   y   ... ]	Square brackets enclose a set of optional syntax choices separated by vertical bars, from which you select one or none.
{ x   y   ... }*	Asterisk marked braces enclose a set of required syntax choices separated by vertical bars, from which you select at least one.
[ x   y   ... ]*	Asterisk marked square brackets enclose optional syntax choices separated by vertical bars, from which you select one choice, multiple choices, or none.
&<1-n>	The argument or keyword and argument combination before the ampersand (&) sign can be entered 1 to n times.
#	A line that starts with a pound (#) sign is comments.


### GUI conventions

Convention	Description
<b>Boldface</b>	Window names, button names, field names, and menu items are in Boldface. For example, the <b>New User</b> window appears; click <b>OK</b> .
>	Multi-level menus are separated by angle brackets. For example, <b>File &gt; Create &gt; Folder</b> .













### Symbols

Convention	Description
 <b>WARNING!</b>	An alert that calls attention to important information that if not understood or followed can result in personal injury.
 <b>CAUTION:</b>	An alert that calls attention to important information that if not understood or followed can result in data loss, data corruption, or damage to hardware or software.
 <b>IMPORTANT:</b>	An alert that calls attention to essential information.
<b>NOTE:</b>	An alert that contains additional or supplementary information.



Convention	Description
 <b>TIP:</b>	An alert that provides helpful information.

## Network topology icons

Convention	Description
	Represents a generic network device, such as a router, switch, or firewall.
	Represents a routing-capable device, such as a router or Layer 3 switch.
	Represents a generic switch, such as a Layer 2 or Layer 3 switch, or a router that supports Layer 2 forwarding and other Layer 2 features.
	Represents an access controller, a unified wired-WLAN module, or the access controller engine on a unified wired-WLAN switch.
	Represents an access point.
	Represents a wireless terminator unit.
	Represents a wireless terminator.
	Represents a mesh access point.
	Represents omnidirectional signals.
	Represents directional signals.
	Represents a security product, such as a firewall, UTM, multiservice security gateway, or load balancing device.
	Represents a security card, such as a firewall, load balancing, NetStream, SSL VPN, IPS, or ACG card.

# Support and other resources

## Accessing Hewlett Packard Enterprise Support

- For live assistance, go to the Contact Hewlett Packard Enterprise Worldwide website:  
[www.hpe.com/assistance](http://www.hpe.com/assistance)
- To access documentation and support services, go to the Hewlett Packard Enterprise Support Center website:  
[www.hpe.com/support/hpesc](http://www.hpe.com/support/hpesc)

### Information to collect

- Technical support registration number (if applicable)
- Product name, model or version, and serial number
- Operating system name and version
- Firmware version
- Error messages
- Product-specific reports and logs
- Add-on products or components
- Third-party products or components

## Accessing updates

- Some software products provide a mechanism for accessing software updates through the product interface. Review your product documentation to identify the recommended software update method.
- To download product updates, go to either of the following:
  - Hewlett Packard Enterprise Support Center **Get connected with updates** page:  
[www.hpe.com/support/e-updates](http://www.hpe.com/support/e-updates)
  - Software Depot website:  
[www.hpe.com/support/softwaredepot](http://www.hpe.com/support/softwaredepot)
- To view and update your entitlements, and to link your contracts, Care Packs, and warranties with your profile, go to the Hewlett Packard Enterprise Support Center **More Information on Access to Support Materials** page:  
[www.hpe.com/support/AccessToSupportMaterials](http://www.hpe.com/support/AccessToSupportMaterials)

---

### ⓘ **IMPORTANT:**

Access to some updates might require product entitlement when accessed through the Hewlett Packard Enterprise Support Center. You must have an HP Passport set up with relevant entitlements.

---

# Websites

Website	Link
<b>Networking websites</b>	
Hewlett Packard Enterprise Information Library for Networking	<a href="http://www.hpe.com/networking/resourcefinder">www.hpe.com/networking/resourcefinder</a>
Hewlett Packard Enterprise Networking website	<a href="http://www.hpe.com/info/networking">www.hpe.com/info/networking</a>
Hewlett Packard Enterprise My Networking website	<a href="http://www.hpe.com/networking/support">www.hpe.com/networking/support</a>
Hewlett Packard Enterprise My Networking Portal	<a href="http://www.hpe.com/networking/mynetworking">www.hpe.com/networking/mynetworking</a>
Hewlett Packard Enterprise Networking Warranty	<a href="http://www.hpe.com/networking/warranty">www.hpe.com/networking/warranty</a>
<b>General websites</b>	
Hewlett Packard Enterprise Information Library	<a href="http://www.hpe.com/info/enterprise/docs">www.hpe.com/info/enterprise/docs</a>
Hewlett Packard Enterprise Support Center	<a href="http://www.hpe.com/support/hpesc">www.hpe.com/support/hpesc</a>
Hewlett Packard Enterprise Support Services Central	<a href="http://ssc.hpe.com/portal/site/ssc/">ssc.hpe.com/portal/site/ssc/</a>
Contact Hewlett Packard Enterprise Worldwide	<a href="http://www.hpe.com/assistance">www.hpe.com/assistance</a>
Subscription Service/Support Alerts	<a href="http://www.hpe.com/support/e-updates">www.hpe.com/support/e-updates</a>
Software Depot	<a href="http://www.hpe.com/support/softwaredepot">www.hpe.com/support/softwaredepot</a>
Customer Self Repair (not applicable to all devices)	<a href="http://www.hpe.com/support/selfrepair">www.hpe.com/support/selfrepair</a>
Insight Remote Support (not applicable to all devices)	<a href="http://www.hpe.com/info/insightremotesupport/docs">www.hpe.com/info/insightremotesupport/docs</a>

## Customer self repair

Hewlett Packard Enterprise customer self repair (CSR) programs allow you to repair your product. If a CSR part needs to be replaced, it will be shipped directly to you so that you can install it at your convenience. Some parts do not qualify for CSR. Your Hewlett Packard Enterprise authorized service provider will determine whether a repair can be accomplished by CSR.

For more information about CSR, contact your local service provider or go to the CSR website:

[www.hpe.com/support/selfrepair](http://www.hpe.com/support/selfrepair)

## Remote support

Remote support is available with supported devices as part of your warranty, Care Pack Service, or contractual support agreement. It provides intelligent event diagnosis, and automatic, secure submission of hardware event notifications to Hewlett Packard Enterprise, which will initiate a fast and accurate resolution based on your product's service level. Hewlett Packard Enterprise strongly recommends that you register your device for remote support.

For more information and device support details, go to the following website:

[www.hpe.com/info/insightremotesupport/docs](http://www.hpe.com/info/insightremotesupport/docs)

## Documentation feedback

Hewlett Packard Enterprise is committed to providing documentation that meets your needs. To help us improve the documentation, send any errors, suggestions, or comments to Documentation Feedback ([docsfeedback@hpe.com](mailto:docsfeedback@hpe.com)). When submitting your feedback, include the document title,

part number, edition, and publication date located on the front cover of the document. For online help content, include the product name, product version, help edition, and publication date located on the legal notices page.

# Index

## A C E F G H I L P S T V

### A

Accessing the IRF fabric to verify the configuration, [43](#)

### C

Chassis views, [46](#)

Configuration terminal problems, [45](#)

Configuring basic IRF settings, [43](#)

Connecting the console cable, [33](#)

Connecting the physical IRF ports, [43](#)

Connecting the power cord, [28](#)

### E

Examining the installation site, [2](#)

### F

Fan failure, [44](#)

### G

Grounding the switch, [21](#)

### H

Hot swappable fan trays, [60](#)

Hot swappable power supplies, [59](#)

### I

Installation tools, [4](#)

Installing the switch in a 19-inch rack, [8](#)

Installing/removing a fan tray, [23](#)

Installing/removing a power supply, [25](#)

IRF fabric setup flowchart, [38](#)

### L

LEDs, [69](#)

### P

Planning IRF fabric setup, [39](#)

Ports, [63](#)

Power supply failure, [44](#)

Powering on the switch, [36](#)

### S

Safety recommendations, [1](#)

Setting terminal parameters, [36](#)

Setting up the configuration environment, [33](#)

### T

Technical specifications, [47](#)

### V

Verifying the installation, [32](#)